



Jerzy WOŁEK

**SPECIES CO-OCCURRENCE PATTERNS
IN PLEUSTONIC PLANT COMMUNITIES
(CLASS LEMNETEA)**

**ARE THERE ASSEMBLY RULES GOVERNING
PLEUSTONIC COMMUNITY ASSEMBLY?**

FRAGMENTA FLORISTICA ET GEBOTANICA
SUPPLEMENTUM 5

JERZY WOŁEK

**SPECIES CO-OCCURRENCE
PATTERNS IN PLEUSTONIC PLANT
COMMUNITIES (CLASS LEMNETEA)**

**ARE THERE ASSEMBLY RULES GOVERNING
PLEUSTONIC COMMUNITY ASSEMBLY?**

W. Szafer Institute of Botany, Polish Academy of Sciences

Kraków 1997

ADVISORY EDITORIAL BOARD

OLGA M. AFONINA (St. Petersburg)	MARTA MIZIANTY (Kraków – Chairman)
ADAM BORATYŃSKI (Kórnik)	DAVID M. MOORE (Reading)
ARTHUR COPPING (Diss)	TAMÁS PÓCS (Eger)
ZBIGNIEW DZWONKO (Kraków)	ARNE STRID (Copenhagen)
JAN-PETER FRAHM (Duisburg)	JERZY ST. SZWAGRZYK (Kraków)
LUDWIK FREY (Kraków)	JERZY SZWEYKOWSKI (Poznań)
KRYSTYNA GRODZIŃSKA (Kraków)	KONRAD WOŁOWSKI (Kraków)
HANNES HERTEL (München)	ADAM ZAJĄC (Kraków)
ZYGMUNT KACZMAREK (Poznań)	KAZIMIERZ ZARZYCKI (Kraków)
STANISŁAW KŁOSOWSKI (Warszawa)	BOGDAN ZEMANEK (Kraków)
TOMASZ MAJEWSKI (Warszawa)	

EDITOR

JERZY WOLEK

EDITORIAL ASSISTANT

MAŁGORZATA MATYJASZKIEWICZ

Editorial Office

W. Szafer Institute of Botany, Polish Academy of Sciences
Lubicz 46, PL–31–512 Kraków, Poland
tel. (012) 21 51 44 fax. (012) 21 97 90 E-mail: wolek@ib-pan.krakow.pl

COVER DESIGN

MICHAŁ SKAKUJ

MAKE-UP EDITOR

MARIAN WYSOCKI

*This volume is published with the financial support
of the State Committee for Scientific Research*

Copyright © W. Szafer Institute of Botany, Polish Academy of Sciences 1997

All Rights Reserved

No part of this book may be reproduced for collective use in any form by photostat, microfilm, or in any other means, without written permission from the publisher

*Published, sold and distributed by W. Szafer Institute of Botany, Polish Academy of Sciences
Lubicz 46, PL–31–512 Kraków, Poland*

Printed in Poland

ISBN 83–85444–48–3

ISSN: 0015–931x

DRUKARNIA KOLEJOWA, KRAKÓW, UL. BOSACKA 6

Species co-occurrence patterns in pleustonic plant communities (class Lemnetaea): are there assembly rules governing pleustonic community assembly?

JERZY WOŁEK

WOŁEK J. 1997. Species co-occurrence patterns in pleustonic plant communities (class *Lemnetaea*): are there assembly rules governing pleustonic community assembly? *Fragmenta Floristica et Geobotanica Supplementum* 5: 3–100. Kraków. PL ISSN 0015–931x.

ABSTRACT: The set of 1945 phytosociological records from Poland was studied for the co-occurrence of the following 9 pleustonic (=free-floating) species: *Lemna minor* L., *Lemna trisulca* L., *Lemna gibba* L., *Spirodela polyrhiza* (L.) Schleid., *Wolffia arrhiza* (L.) Wimm., *Salvinia natans* (L.) All., *Ricciocarpos natans* (L.) Corda, *Riccia fluitans* L. and *Hydrocharis morsus-ranae* L. All relevés in which at least one of the species considered had been found and all aquatic habitats throughout Poland, including diverse types of water body, as well as diverse plant communities inhabited by pleustonic species were taken into account. The aim of this study was to examine whether or not associations of pleustonic plant communities can be classified (according to the Braun-Blanquet phytosociological approach) on the basis of their own character species and on the environmental conditions indicated by them. In this context, two questions were considered: (1) whether the combinations of pleustonic species observed in nature are determined by any ecological factor(s), and (2) whether or not the observed frequency distribution of pleustonic species combinations is random. The results obtained are compatible with Gleason's individualistic hypothesis of the plant community. It is concluded that the floristic composition of a given pleustonic assemblage is determined by a combination of abiotic factors and random events, and species interactions have no impact on it. This means that the assemblages of pleustonic species under consideration may be treated as but random subsets of a given species pool. This finding supports the view that any syntaxonomical scheme for pleustonic plant communities based on floristic criteria must fail for this very reason. Within a given habitat type pleustonic assemblages should be considered in terms of their species combinations, if necessary.

KEYS WORDS: pattern, process, mechanism, community assembly, assembly rules, community, assemblage, null model, null hypothesis, research hypothesis, pleustonic plants, lemnids, *Lemnetaea*, syntaxonomy

J. Wołek, Laboratory of Plant Ecology, W Szafer Institute of Botany, Polish Academy of Sciences, ul. Lubicz 46, PL–31–512 Kraków, Poland; E-mail: wolek@ib-pan.krakow.pl

CONTENTS

1. INTRODUCTION	5
1.1. Controversy on plant community theory	5
1.2. Conceptual background of the study	6
1.3. Controversy on syntaxonomic schemes in pleustonic plant communities	8
1.4. What are the main factors determining the species composition of pleustonic plant communities? – review of the author's previous investigations	9
1.5. Aim of the study	10
2. MATERIAL	10
3. METHODS	11
3.1. Remarks on terminology used	11
3.2. Methodological framework for dealing with community assembly	12
3.3. Sampling procedure	12
3.4. Analysis of data: hypotheses tested and statistical methods used	12
3.4.1. Question 1: whether or not the combinations of pleustonic species observed in the field are determined by any ecological factor(s)	12
3.4.2. Question 2: whether or not the observed frequency distribution of pleustonic species combinations is random	14
3.5. Explanation of frequently used abbreviations	16
4. RESULTS	16
4.1. Structure and representativeness of the set of data under study	16
4.2. Relationships between pleustonic species assemblages and some ecological factors	27
4.2.1. Influence of water pH on the number of pleustonic species per relevé	27
4.2.2. Influence of water body type on the number of pleustonic species per relevé	35
4.2.3. Influence of the type of helophytic and aquatic vegetation on the number of pleustonic species per relevé	38
4.2.4. Influence of both characteristics, the type of helophytic vegetation and type of water body, on the number of pleustonic species per relevé	38
4.3. Observed frequency distribution of pleustonic species combinations is random	40
4.3.1. Observed frequency of <i>k</i> -species combinations follows the binomial distribution	40
4.3.2. Observed frequency distribution of <i>k</i> -species combinations and frequency of occurrence of individual species combinations follow null model expectations	41
5. DISCUSSION	51
5.1. Data collection under study	51
5.2. Relationships between pleustonic species assemblages and ecological factors	54
5.3. Species co-occurrence patterns in pleustonic assemblages are random	63
5.4. The syntaxonomy of pleustonic communities	68
APPENDICES	72
APPENDIX A: Community or assemblage	72
APPENDIX B: Pattern, process, mechanism	73
APPENDIX C: Assembly rules	75
APPENDIX D: Null model and null hypothesis	76
APPENDIX E: Chance and randomness	78
APPENDIX F: Methodological framework for dealing with community assembly	79
APPENDIX G: Consequences of rejecting or accepting the null hypothesis	81
APPENDIX H: Second version of the null model	82
APPENDIX I: The binomial distribution in ecology	83
REFERENCES	86

1. INTRODUCTION

1.1. Controversy on plant community theory

The concept of the plant community is a matter of long debate. Vegetation scientists have tried to answer the question as to whether communities are groups of different species populations structured by biotic interactions (and to what degree) or are mere assemblages of these populations. F. E. Clements and H. A. Gleason are identified as the pioneers of the two distinct schools of thought as to how plant communities are organized (Austin 1986).

One school grew out of the *organismal association theory* proposed by Clements (1916, 1928, 1936). According to his original idea, the plant community, like an organism, is born, grows, matures, reproduces and dies, and these developmental stages, or successional related communities, can be interpreted as an organismic entity. Many considered this organismic analogy as rather unrealistic and inconsistent with reality and rejected it (e.g. Tansley 1920, 1935). Later, in place of Clements's organismic association theory, Whittaker (1956, 1962) proposed the *community-unit theory*. This theory is based on the assumption that some fundamental unit of natural plant community does exist. This unit is *natural* in the sense that it is present in the structure of natural communities and is not a product of human classification. Proponents of this theory believe that plant communities are highly self organized discrete recognizable entities, with a definite structure resulting from biotic interactions. Interspecific competition is to be considered the main structuring force in community ecology. Under this idea biotic interactions act to maintain plant communities at or near equilibrium.

Opposed to the Clementsian theory is the view, following the *individualistic concept* proposed by Gleason (1917, 1926, 1939), that plant communities are mere random assemblages of individual species adapted to the particular environment in a location. It is assumed that variable and unpredictable abiotic factors are pre-eminent and that certain species are found together because the locally suitable environmental conditions of the moment favour them in preference to other species. Each species responds in its own, individual and independent way to the ecological gradients. Vegetation is therefore considered to be a continuum of communities of gradually changing composition.

Although Gleason is widely regarded as the main creator of the individualistic concept this is not the case. Multiple and independent discoveries of the concept occurred (Whittaker 1962; McIntosh 1975).

Gleason's individualistic concept was supported simultaneously and independently by Curtis's vegetational continuum and Whittaker's gradient analysis (McIntosh 1967a; Whittaker 1967). Their ideas were later termed the *(community) continuum concept*. While the continuum concept is considered to be the intellectual descendant of the individualistic concept (Ponyatovskaya 1961; McIntosh 1967a; Whittaker 1967; Collins *et al.* 1993), the two concepts should not be used synonymously. As has been pointed out, continuous intergradation of communities may occur even without individualistic species patterns (Goodall 1963, see also Collins *et al.* 1993). Nevertheless, many ecologists have embraced both concepts under the joint term *individualistic continuum*.

Whether plant (as well as animal) communities are *integrated* or *individualistic*, *continuous* or *discontinuous*, is a central and continuing issue of community ecology (Strong *et al.* 1984; Austin 1986; Underwood 1986; Wilson & Allen 1990; Drake 1990; Allan 1995). This controversy has persisted for the whole of this century. It has been reviewed by McIntosh (1993, and references therein). This still unsolved question remains at the core of the discussion in vegetation science (Shipley & Keddy 1987; McIntosh 1993). McIntosh (1993) suggests that the issues of continuity and discontinuity of vegetation are not likely to be resolved by the year 2000.

Some authors (Mirkin 1987; Minchin 1989; Auerbach & Shmida 1993) suggested that the continuum concept has become a prevailing paradigm in modern vegetation science, but Barkman (1990) was of a different opinion.

The continuum and community-unit concepts are frequently viewed as antithetical (Shipley & Keddy 1987; Roberts 1987), but it is to be emphasized that the two can also be viewed as extreme cases of dynamical systems, i.e. that plant communities can range from discrete to continuous. It is not therefore necessary to hypothesize that the *true* nature of vegetation is either continuous or discontinuous (Roberts 1987; Auerbach & Shmida 1993). Depending on circumstances, either extreme or any point in between may occur.

The above-mentioned concepts are only extremes of the scale of opinion as to how plant communities are assembled. They emphasize only some of the ecological factors generating community structure, but, as is well known, nature is multifactorial, and, as a consequence, many interacting factors, abiotic and biotic, may contribute to the existence of community patterns. How the interacting processes may influence a community and its structure have given rise to a number of different community theories. Some of these theories have been developed in animal community ecology and may thus have seemed irrelevant to most plant ecologists. However, they raise questions which need to be considered in the field of plant community ecology too. Various community theories, comprising early and new ideas, have been reviewed and discussed by Whittaker (1962, 1967, 1978a, b), Goodall (1963), Mueller-Dombois and Ellenberg (1974), Grubb (1977), Grime (1979), Price (1984), Austin (1985), McIntosh (1967a, 1975, 1993), Chesson and Case (1986), Giller and Gee (1987), Noy-Meir and van der Maarel (1987), Austin and Smith (1989), Crawley (1989a), Moravec (1989), Grace and Tilman (1990), Collins *et al.* (1993), Mirkin (1994), Allan (1995), to mention only some.

1.2. Conceptual background of the study

The continuum concept has its proponents primarily in the Anglo-American world whereas the community-unit concept is favoured amongst European vegetation scientists. As Glavac *et al.* (1992) emphasize, the idea that plant communities could be described and classified has seemed to point so obviously to the latter that the community-unit/continuum controversy has hardly been investigated. This has resulted from the fact that European approaches to the study of vegetation all started from the community-unit theory, which implies that vegetation consists of community types representing well-defined

natural entities, which are part of the structure of vegetation and which generally contact one another along narrow boundaries (Whittaker 1956, 1962, 1967).

One of the most famous European approaches is the one presented by Braun-Blanquet (1921, 1932), known also as the Swiss-French or Zürich-Montpellier approach (but in this respect see van der Maarel 1975). At present his approach to classification and interpretation of communities is the most widely accepted by vegetation scientists (Mueller-Dombois & Ellenberg 1974; Whittaker 1978a; Barkmann 1990). It is argued that this approach represents a scientifically sound, versatile and efficient classification method (Werger 1974). Limitations to the approach have been commented on by Poore (1955a, b, c, 1956) and Whittaker (1962).

Braun-Blanquet never considered the plant community (or association in his terminology) as a *superorganism* but nevertheless he saw in the individual plant community (plant stand or phytocoenosis) a higher form of organization (Mueller-Dombois & Ellenberg 1974; van der Maarel 1975; Glavac *et al.* 1992). He regarded the plant community as the basic unit of vegetation classification just as the species is considered to be the basic unit in the taxonomic classification system of organisms (Mueller-Dombois & Ellenberg 1974; Westhoff & van der Maarel 1978).

The Braun-Blanquet approach is based on the observation that some individual plant communities (or species combinations) are found much more frequently than others (Noy-Meir & van der Maarel 1987). In general, some characteristic elements of the approach can be summarized as follows (van der Maarel 1975).

Plant communities are conceived as types of vegetation – associations (i.e. abstract units). They are recognized by their full species composition, but of major importance, however, are diagnostic species (i.e. character species, differential species and so on) being species with narrow ecological amplitudes. The group of diagnostic species forms the so-called *characteristic species combination* which is the most sensitive expression of some ecological relationships. With the help of the characteristic species combination, individual plant communities or phytocoenoses (i.e. concrete units) occurring in the field can be identified as members of a particular community type or association. This conceptual framework is consistent with the community-unit view that the spatial structure of vegetation changes discontinuously along an environmental gradient. Longer or shorter transition zones or boundaries exist between adjacent individual plant communities, and groups of ecologically and sociologically interrelated species repeatedly occur in these zones. For our purposes, the above may be expressed in a more operational form as follows.

1. Assumptions.

1.1. Individual plant communities (phytocoenoses) result from the responses of individual species to the habitat; these responses are reinforced and modified by strong positive dependences between plant species (Noy-Meir & van der Maarel 1987).

1.2. Similar individual plant communities come into existence in similar ecological, biogeographical and historical conditions (Matuszkiewicz 1981).

2. Consequences.

2.1. Individual plant communities are recurrent natural entities.

2.2. Recurrence of individual plant communities makes recognizing plant community types possible.

2.3. Each plant community type has its own characteristic species combination which is an indication of specific species–species and species–habitat ecological relationships.

2.4. The recurrence of individual plant communities provides an argument in favour of the view that some species combinations are not episodic. Consequently a non-random pattern of observed frequencies of occurrence of species combinations comes into being.

Of the above mentioned consequences, the two last are considered in this study in relation to pleustonic or free-floating water plants.

1.3. Controversy on syntaxonomic schemes in pleustonic plant communities

The syntaxonomy of pleustonic plant communities is a source of argument. Two major issues of long standing debate are (1) the syntaxonomic position of these communities in the hierarchical system of Braun-Blanquet (i.e. whether pleustonic communities should be considered as the separate class *Lemnetea* or not?) and (2) the problem of characteristic species of the higher and lower syntaxa. A detailed discussion of these questions is beyond the scope of this paper. For more information on these topics the reader is referred to papers by Slavnić (1956), Oberdorfer (1957), Miyawaki and Tüxen (1960), Müller and Görs (1960), den Hartog and Segal (1964), Segal (1968), de Lange (1972), Wołek (1974a), Passarge (1978), Schwabe-Braun and Tüxen (1981a, b), Scoppola (1982) and Landolt (1986).

European pleustonic communities are included in the alliance *Lemnion minoris* W. Koch & R. Tx. (in lit 1954) apud R. Tx. 1955 (Landolt 1986), but the classification of communities is not generally agreed on. Individual authors distinguish different numbers of associations. Passarge (1978), for example, has described 17 associations for Central Europe, whereas Schwabe-Braun and Tüxen (1981b) have distinguished only 5 for Europe as a whole. In Landolt's (1986) opinion, it does not make much sense to have so many associations if we take into consideration the small number of species present in the different associations and seasonal changes occurring in the species composition. Wołek (1974a) was of the same opinion in this respect.

The suspicion grows that in this context such different classifications result from the subjective approach of individual scientists and do not reflect the actual compositional structure of the pleustonic communities in nature. On the other hand, however, one cannot ignore the correlations between the distinguished associations and certain abiotic factors. The role of biotic interactions (especially competition as a major structuring force) must also be emphasized (see Landolt 1986 and references cited therein). Some scientists (e.g. Pott 1981 acc. to Landolt 1986) report the value of the associations as bioindicators.

1.4. What are the main factors determining the species composition of pleustonic plant communities? – review of the author's previous investigations

The issue discussed in the previous unit, which is important both from a practical as well as a theoretical point of view, relates directly to the community-unit/continuum controversy mentioned earlier. In the past the present author has approached it from both standpoints. The results obtained are concisely given in this section. Results from other workers have not been included in this review because they have been described elsewhere. For details the reader is referred to the author's papers cited below.

First of all, previously gathered information on the phytosociology and ecology of the pleustonic communities of Poland, methods of analyzing their structure and habitat conditions were critically reviewed (Wolek 1974a). A set of native relevés belonging to the alliance *Lemnion minoris* was also analyzed for the occurrence of combinations of pleustonic species. On the basis of presence/absence data, and the phytosociological and ecological information concerning these species, 3 associations were distinguished for Poland instead of the 10 existing hitherto in the Polish phytosociological literature (Wolek 1974a). It was, however, interesting to consider exactly what factors were responsible for the floristic composition of pleustonic communities as observed in nature. Of the ecological factors influencing the community structure, interspecific competition for limited resources and allelopathy were considered to be of prime importance (Wolek 1974b, 1979 and references cited therein). For this reason, in the next stage, experimental investigations were carried out on competition and allelopathy among some species of Lemnaceae (Wolek 1974b, 1979, 1984). The experiments showed (1) two types of interactions to exist: competition for mineral salts and allelopathic action of plants on one another, (2) the decisive role of the morphological features of the studied species in interspecific competition for nutrients (i.e. species with longer roots and/or stronger developed underwater parts reach deeper into the nutrient solution and appear to be better competitors), (3) the occurrence of different competitive abilities in different species as well as in different clones of the same species, and (4) the different sensitivities of individual species to the allelopathic influence of metabolites released by plants into the nutrient solution.

These results suggested that the floristic composition of a given pleustonic community may result from the two biotic interactions, especially from competitive exclusion, but the other ecological factors may also influence the community structure. The absence of certain pleustonic species in a community might, for example, result from ineffective dispersal (Wolek 1981). It may also be the result of random dispersal, i. e. it follows some probability distribution. This research hypothesis was tested by means of a null model. In particular, the hypothesis that pleustonic species occur independently and randomly was tested. The results obtained suggested (Wolek 1983) that the different combinations of pleustonic species, recorded in relevés, could be considered random. The frequencies of occurrence of these combinations, however, might also have been determined by some abiotic and/or biotic factors. The subsequent investigations provided evidence that differences found in the species composition of the pleustonic communities

could be sufficiently explained by assuming that species disperse independently and randomly and that their distribution is influenced by environmental abiotic factors (Wołek 1991).

The research presented in this paper is a continuation of the studies briefly described above.

1.5. Aim of the study

The aim of this study is to examine whether or not associations of pleustonic plant communities can be classified (according to the Braun-Blanquet phytosociological approach) on the basis of their own character species and on the basis of the environmental conditions indicated by them. In this context, two questions are considered: (1) whether combinations of pleustonic species observed in nature are determined by any ecological factor(s), and (2) whether or not the observed frequency distribution of pleustonic species combinations is random.

2. MATERIAL

Assemblages of pleustonic plants are commonly found in different types of water body. They consist, usually, of a small number of pleustonic species, nine of which occur in Poland, namely: *Lemna minor* L., *Lemna trisulca* L., *Lemna gibba* L., *Spirodela polyrhiza* (L.) Schleid., *Wolffia arrhiza* (L.) Wimm., *Salvinia natans* (L.) All., *Ricciocarpos natans* (L.) Corda, *Riccia fluitans* L. and *Hydrocharis morsus-ranae* L. Except for the last, all the species listed above are universally considered as species characteristic of the class *Lemnetea*. As to *H. morsus-ranae*, it has been treated as characteristic of the class *Lemnetea* W. Koch & R. Tx. 1954 (Müller & Görs 1960; Kępczyński 1965; Polakowski & Dziedzic 1972; Passarge 1978), of the class *Potamogetonetea* R. Tx. & Preisg. 1942, the alliance *Nymphaeion* W. Koch 1926 (Podbielkowski & Tomaszewicz 1974; Tomaszewicz 1977a, 1980; Matuszkiewicz 1981) or of the class *Stratiotetea* den Hartog & Segal 1964 (den Hartog & Segal 1964; Segal 1968). For the purpose of the present study, the diagnostic value of *H. morsus-ranae* seems to be of little importance. This species often occurs with other pleustonic plants. It may be concluded, then, that *H. morsus-ranae* has almost the same habitat requirements as the other pleustonic species (Wołek 1974a). Consequently, it would appear that this provides a good enough reason for including it in the group of species considered. The results obtained during subsequent investigations (Wołek 1983) also support this decision.

The pleustonic plants considered belong to a group of plants with the same type of life form. This group (=layer, stratum) or synusia forms the so-called *lemnids*. Following Jensen and van der Maarel (1980), the concept of an aquatic phytocoenosis as a synusial combination (i.e. a combination of all types of life form) is adopted here. The phytocoenosis may consist of one or many synusiae. In the first case, the other layers are considered to have an actual representation of zero. Phytocoenoses belonging to pleustonic associations such as e.g. *Lemnetum gibbae*, *Wolffietum arrhiza*, *Ricciatum fluitantis* etc. are examples here. Thus, such a mobile synusia is, in practice, an individual plant community itself. Therefore, pleustonic phytocoenoses will hereafter be called *autonomous pleustonic phytocoenoses* or *autonomous synusiae* (AS). In the second case, lemnids occur in combination with other synusiae, e.g. helophytes, nymphoids, elodeids, isoetids and so on. Thus, lemnids form only one of several layers growing above, below, beside or in the mixture. In such a situation, lemnids are just a component of the individual plant community. Phytocoenoses belonging to aquatic and helophytic associations such as e.g. *Typhetum latifoliae*, *Phragmitetum*, *Acoretum calami*, *Elodeetum canadensis*, *Myriophylletum spicati*, *Trapetum natantis* etc. are examples here. Further such examples can be found in Wołek (1991). Lemnids inhabiting such phytocoenoses will hereafter be called *non-autonomous pleustonic assemblages* or *non-autonomous synusiae* (N-AS).

The subset *autonomous synusiae* embraces relevés representing either pleustonic associations belonging to the alliance *Lemnion minoris* W. Koch & R. Tx. 1954 or to the association *Hydrocharitetum morsus-ranae* van Langendonck 1935. The subset *non-autonomous synusiae* embraces relevés representing aquatic and helophytic associations, the phytocoenoses of which are inhabited by lemniids.

The syntaxonomic classification of aquatic and helophytic vegetation mainly follows Tomaszewicz (1980) with the exception of the association *Hydrocharitetum morsus-ranae*. Because this association is a type of one-synusia plant community like the other pleustonic associations (see above, this section), it has not been placed in the alliance *Nymphaeion*, as was proposed by Tomaszewicz (1980). Relevés representing phytocoenoses of this syntaxon were therefore placed in the subset comprising relevés belonging to the alliance *Lemnion minoris*.

It is to be expected that competition for common resources among member species of the same life form growing together is stronger than among species of the same community belonging to different synusiae (Mueller-Dombois & Ellenberg 1974). Therefore, using a synusial approach to investigations of interspecific competition – a potential factor in community assembly – we can easily reveal this interaction, if only it exists (e.g. Wilson & Sykes 1988; Wilson 1989).

3. METHODS

3.1. Remarks on the terminology used

Ecological and phytosociological terms are usually defined in different ways (e.g. Curtis & McIntosh 1950; Carpenter 1950; Whittaker 1962; Daubenmire 1966; Jonckers 1973; Peet 1974; Wiens 1976; Rejmánek 1977; Ravera 1984; Chapleau *et al.* 1988; Simberloff & Dayan 1991, to mention only some). Precise terminology is crucial in any science. It is well known that no definition can be claimed as more, or less, correct than another, since all definitions are arbitrary, but, on the other hand, different definitions of a term lead to different interpretations of the same observations (Allen & Hoekstra 1992). As Loehle (1988) noted, “in the absence of clear definitions debates have raged *ad nauseum* in ecology.” According to many, progress in ecology, as in all sciences, depends upon precise and unambiguous definitions of terms (Mason & Langenheim 1957; McIntosh 1967b; Austin 1968). All scientific vocabularies reflect a conceptual framework (Allen & Hoekstra 1992). Hence, to avoid misunderstanding, terms used in this paper such as: community and assemblage; pattern, process and mechanism; assembly rules; null model and null hypothesis; chance and randomness, have been discussed and defined as far as seems appropriate and possible for the purpose of the study (see Appendices A–E). Some statistical and ecological terms are explained below.

Community assembly or phytocoenogenesis: an ecological process as a result of which either a plant assemblage or plant community is formed.

Habitat: the dwelling place (not locality or exact place of occurrence) of a given organism, population or biocoenosis. This term may be interpreted in different ways according to the level of organization considered. The habitat of an organism or a population depends on abiotic and/or biotic factors. These last are a result of intra- and interspecific as well as non-specific interactions. The habitat of a biocoenosis depends on abiotic factors only (Odum 1963, see also Braun-Blanquet 1932).

Homogeneous samples: samples are considered homogeneous if they are in statistical agreement (Kendall & Buckland 1960).

***k*-species combination:** combination composed of $k = 1, 2, \dots, n$ pleustonic species, where n means the maximum, potentially possible number of pleustonic species in a combination ($k \leq n$).

Pleustonic assemblage: a one or multispecies set of populations of pleustonic plants occurring in a given area.

Pool of species: in a considered ecological situation the number of potentially available species which are able to immigrate to any available habitat, whether they can persist there or not (acc. to MacArthur & Wilson 1967, with minor modifications).

Representative sample: this term means a sample which is representative of a statistical population in respect of certain characteristics (Kendall & Buckland 1960).

3.2. Methodological framework for dealing with community assembly

As each observation is embedded within a theory and has resulted from a specific methodological framework, any scientific activity is inevitably based on some research program which dictates decisions on relevant theory and what constitutes an appropriate methodology. It seems that in any scientific activity the most important matter is to carry out investigations according to the one chosen research program until new data enforce its modification or rejection in favour of another program. In this way, a researcher will be able to realize that he is wrong sooner than would have been the case had he had no clear plan of investigation. The conceptual background of the investigations presented here has been discussed earlier (section 1.2). The methodological framework is briefly presented in Appendix F.

3.3. Sampling procedure

The investigations presented in this paper are based on a collection of relevés which were made by means of the Braun-Blanquet method. Although some are of different opinion (Werger 1974 and references cited therein), this method has often been criticized for the subjectivity of the sampling procedure (e.g. Gleason 1926; Goodall 1954; Poore 1955a, b, c, 1956; Moore 1962, see also Whittaker 1962; Kershaw & Looney 1985). This means that stands in which relevés are made are selected intentionally so the collection of relevés thus obtained is not a random and representative sample as defined by Kendall and Buckland (1960). This question is of great importance because a statistical inference based on such a sample may lead to biased conclusions. Zasepa (1962) and Barnett (1982), among others, stressed this aspect of statistical analysis. To avoid such a danger, an attempt was made to obtain a representative sample of the statistical population in respect of all combinations of pleustonic species occurring in nature and all the habitats along the environmental gradient inhabited by the species. To achieve this aim, all relevés in which at least one of the species considered was found and all aquatic habitats throughout Poland, including diverse types of water body as well as diverse rooted plant communities inhabited by pleustonic species, were taken into account. Thus, the area of investigation is situated within overlapping geographical ranges of the species in question and within one climatic region (see Landolt 1986). In this way a collection of 1945 relevés, originating from 44 phytosociological papers from the period 1960–1977, concerning pleustonic communities and assemblages from Poland, was used in the study. The same material had been used earlier (Wołek 1983). Newer relevés were not taken into account so that the present results are comparable with those obtained previously by Wołek (1983).

3.4. Analysis of data: hypotheses tested and statistical methods used

3.4.1. Question 1: whether or not the combinations of pleustonic species observed in the field are determined by any ecological factor(s)

Regarding this question, three research null hypotheses were tested, namely: the occurrence of individual pleustonic species and their combinations is independent of (1) water pH, (2) water body type, and (3) type of aquatic and helophytic vegetation. The statistical forms of these hypotheses are presented in subsequent parts of this paper.

Water pH

Water pH is considered to be responsible for the distribution of plants. According to Braun-Blanquet (1932), each plant association has its own definite tolerance of pH values, with a more or less distinct

optimum. As regards pleustonic assemblages, many observations suggesting that individual pleustonic associations develop for a particular range of the pH value of water may be found in various phytosociological papers (e.g. Kępczyński 1965; Podbielkowski 1960, 1967, 1968; Tüxen 1974; Tomaszewicz 1980; Starfinger 1985). It is suggested that this relationship results from the fact that individual pleustonic species vary in their tolerance of the water pH. Some results of laboratory experiments and field observations (Iversen 1929; Hicks 1932; Podbielkowski 1960, 1967 and others) seem to support this opinion. On the other hand, however, Landolt (1957) obtained different results with regard to Lemnaceae species. According to this author, the occurrence of individual species is independent of the pH value of the water. Wołek (1974a) came up with the same conclusion so this question is still open. Therefore, the aim of this investigation is to examine thoroughly the possible influence of water pH on the occurrence of pleustonic plant species and their assemblages. Statistical analysis is based on the subset of 726 relevés having precisely recorded pH values of the water (subset B; Fig. 1).

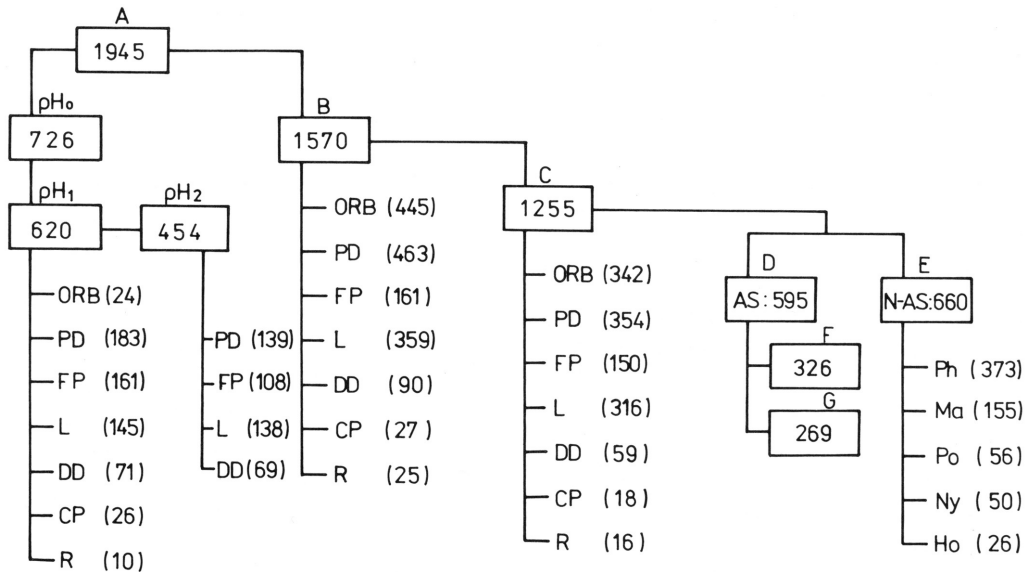

Fig. 1. Diagram illustrating the construction of consecutive subsets of relevés by selecting them from the whole collection of relevés. For details see text. The numbers of relevés belonging to a particular subset are shown in parentheses or rectangles. **A** – whole collection of relevés; **pH₀** – subset of relevés in which the water pH values are accurately recorded; **pH₁** – subset of relevés in which the water body type is precisely determined; **pH₂** – subset comprising only those data samples which are sufficiently large for the chi-square test; **B** – subset of relevés in which the water body type is precisely determined; **C** – subset of relevés that have been assigned to a definite plant association; **D** – subset of relevés (called *autonomous synusiae*, AS) representing phytocoenoses belonging either to the alliance *Lemnon minoris* (subset F) or to the association *Hydrocharitetum morsus-ranae* (subset G); **E** – subset of relevés (called *non-autonomous synusiae*, N-AS) representing aquatic and helophytic plant associations, the phytocoenoses of which are inhabited by lemniids. For explanation of the remaining abbreviations see Section 3.5.

Water body type and vegetation type

Apart from the water pH, the type of water body and the type of aquatic and helophytic vegetation may be considered as possible determinants of the occurrence of pleustonic species and the floristic composition of their assemblages. Such “factors” have of course a complex character – simultaneously physical and biotic (Austin 1980; Wołek & Pancer-Kotejowa 1988).

One may assume that the different sets of ecological factors underlying different types of water body,

as well as different plant associations, affect any propagule of a pleustonic plant entering a particular water body or phytocoenosis, and thereby determine whether or not this propagule becomes established in this water body or phytocoenosis and, in consequence, determine the floristic composition of the given pleustonic assemblage.

The research hypothesis that the water body type affects an assembly of pleustonic assemblages has not, to my knowledge, been examined, although relevant information can be found in some papers (e.g. Krzywańska & Krzywański 1972; Podbielkowski 1960, 1967, 1968, 1969; Rejmánková 1974; Tomaszewicz 1969, 1977a).

As to the influence of vegetation type on the formation of a mobile synusia, an attempt was made by Wołek (1991) to assess how different phytocoenoses influence the patterns of occurrence of pleustonic species growing within them.

The aim of this investigation is to examine the possible influence of water body type and vegetation type combined on the observed patterns of species composition of pleustonic assemblages. In the statistical analysis, various subsets of the relevés shown in Fig. 1 were used as the analysis progressed. These investigations were based on presence/absence data.

In order to test some statistical null hypotheses that stem from the hypotheses presented in this section, different chi-square tests, the Kolmogorov-Smirnov two-samples test and the k -sample Smirnov test have been used (Siegel 1956; Conover 1971; Norcliffe 1986).

3.4.2. Question 2: whether or not the observed frequency distribution of pleustonic species combinations is random

The operational form of this question is that there is no significant difference between the observed distribution of the numbers of species per relevé (= k -species combinations) and a random one. Following Wołek (1988), two different methods were used to test this hypothesis: a conventional statistical test of the goodness-of-fit type, and the null model approach. The same methods for detecting species associations from presence/absence data had been used earlier by Taylor (1979).

In the first case, the statistical null hypothesis was tested that the observed frequency distribution of the k -species combinations (= number of pleustonic species per relevé) had a binomial frequency distribution. As the zero class ($k = 0$) was missing (there were no "empty" relevés with respect to the species considered) the observed distribution was treated as a truncated one. It should therefore be compared with the truncated binomial distribution and the method described by Wołek and Dawidowicz (1991) has been used to calculate the frequencies necessary for this purpose. The agreement of the observed frequencies with the expected ones was tested by means of the one-sample chi-square test.

In the second case, the statistical null hypothesis was tested that the observed frequency distribution of the pleustonic species combinations does not deviate from a random one under the null model expectation. If there were no significant difference between the random and observed distributions compared, the null hypothesis was accepted.

Both the failure to reject and the rejection of the null hypothesis and its concomitant null model raise the question as to what can be inferred in such cases. This question is discussed in detail in Appendix G. From the results of this discussion it is concluded that stochastic events or deterministic factors, respectively, are responsible for the observed pattern.

The expected random species combinations, or so called *null communities*, are assembled randomly from the relevant species pool. The null model used here to construct the null communities has been described and discussed in detail elsewhere (Wołek 1983, 1988). It will only briefly be described here.

Null models are based on co-occurrence or presence/absence data. Such data can be presented in the form of a presence/absence matrix. Its rows are considered as species and its columns as sites, in our case relevés. The digits 1 and 0 respectively indicate the presence and absence of a species in a given site. When counting the presence of species in rows and columns, marginal totals of rows and columns are obtained, respectively.

There is no general agreement on what constraints should be built into a null model (e.g. Harvey *et al.* 1983; Strong *et al.* 1984; Schluter 1984; Wilson 1987; Wołek 1988; Roberts & Stone 1990; Jackson

et al. 1992). Particularly controversial are three null model constraints originally used by Connor and Simberloff (1979), namely:

(1) species (or row) totals in the null model are fixed at those observed, i.e. a notional species occupies the same number of sites as does its corresponding real species;

(2) sites (or column) totals in the null model are fixed at those observed, i.e. a notional site contains the same number of species as does its corresponding real site;

(3) notional species, like real ones, are limited to the observed incidence functions. The concept of incidence functions (called also *incidence ranges*) was introduced by Diamond (1975). This concept suggests that a given species is restricted to a given island size class. In other words it means that a given species never occurs on islands containing less than s' or more than s'' species (Roberts & Stone 1990).

The observed frequencies can be taken as fixed totals (e.g. Connor & Simberloff 1979; Wilson 1987) or as probabilities of occurrence (e.g. Gilpin & Diamond 1982; Alatalo 1982; Wolek 1983, 1988). Both approaches have their proponents and are the subject of long standing debate (e.g. Strong *et al.* 1984; Wilson 1987; Wolek 1988; Jackson *et al.* 1992).

The null model applied in this study is based on the following assumptions.

(1) Null communities were assembled from a pool of potentially available pleustonic species. The species in the pool were those found in the relevant subset of relevés under study. In the case of the whole collection of relevés the number of species found equalled the number of all pleustonic species occurring throughout Poland.

(2) The proportions of species in the pool were their observed frequencies (i.e. species or row totals) taken as probabilities. It was the only constraint built into the null model. The relevé or column totals (second constraint) were not included. It was assumed that the area of a relevé was always large enough to ensure the presence of an optional combination of pleustonic species, so differences observed in the number of species per relevé merely resulted from random dispersion of the species. Connor and Simberloff (1978) and Simberloff (1978) considered the differences in species proportions in the pool to be a measure of the colonization abilities of the species: a species which inhabited more sites was a better colonizer. Because of the lack of a distinct resource area in our case, it was impossible to disprove this hypothesis. All pleustonic species are therefore assumed to have an equal potential to colonize all sites and only a statistical relation exists between this potential and the proportion of a given species in the pool. By relaxing the constraint of column (or site) marginal totals one may assume that all sites are equally suitable for all species in the pool, i.e. the probability of entering any site equals $1/N$, where N represents the number of relevés in the subset considered.

(3) Species were assumed to disperse randomly and independently of one another in space. Thus, the model is completely neutral with respect to any form of species interaction.

The construction of null communities follows a method which is based on the order or sequence in which the individual notional species were originally obtained with the use of a random number generator. To construct null communities, notional species are joined together according to the rule "there are no identical species in a null community". Let us consider an example. Imagine a series of symbols of notional pleustonic species generated in the following order: *Lm Ltr Sp Sp W Lg W Sal Sp Lm Lm Lm Lm*. Following the rule outlined above, we group these symbols into null communities by underlining each succession of different symbols as follows: *Lm Ltr Sp Sp W Lg W Sal Sp Lm Lm Lm Lm*. Thus, in this example, we obtain 6 null communities.

The generation of random species combinations was ended when the total number of these combinations was equal to the total number of observed ones (in practice to the total number of relevés), considered with respect to the given subset of relevés.

Formerly Wolek (1988) recommended that a given computer simulation used to construct random species combinations should be repeated 30 times. Latter, however, it was found that the mean value of the frequencies of occurrence of individual species combinations, calculated on the basis of a 30-fold computer simulation, differed only slightly from that calculated for data obtained using a 10-fold simulation. As a rule, differences were of the order of one decimal place. In contrast, a distinct discrepancy

was found between the result of one simulation and that obtained using a 10-fold simulation. It is evident, of course, that multiple simulation minimizes the consequences of the operation of chance. It was found, however, that, for our purposes, 10-fold simulation was quite sufficient to assess the differences between the generated and observed frequencies. We arrived at the same conclusion when the total number of different species combinations was taken into account; by means of the 10-fold repeated simulation under the null model, all categories of k -species combinations, in the proportions observed in a test-data sample, were generated. In the case when the theoretically possible number of different k -species combinations was small, i.e. when the number of species in the pool, n , or the probability of success, p , was small, all the different combinations, in the proportions observed in a test-data sample, were generated. This latter situation arose in the present study. For the reasons mentioned above, in the present work, each simulation under the null model, with respect to a given species pool, was repeated 10 times.

Agreement between the actual and expected data obtained with the help of computer simulation was estimated by means of the method proposed by Wolek (1988). For details see section 4.2.2.

3.5. Explanations of frequently used abbreviations

Abbreviations used for pleustonic species names – **Lm**: *Lemna minor*; **Ltr**: *Lemna trisulca*; **Lg**: *Lemna gibba*; **Sp**: *Spirodela polyrhiza*; **H**: *Hydrocharis morsus-ranae*; **W**: *Wolffia arrhiza*; **Sal**: *Salvinia natans*; **Rfl**: *Riccia fluitans*; **Ric**: *Ricciocarpus natans*.

Abbreviations used for the phytosociological units – **AS**: autonomous synusiae (phytocoenoses belonging to the alliance *Lemnion minoris* and to the association *Hydrocharitetum morsus-ranae*); **N-AS**: non-autonomous synusiae or pleustonic assemblages inhabiting phytocoenoses of aquatic and helophytic associations; **Le**: *Lemnion minoris* W. Koch & R. Tx. 1954; **Hy**: *Hydrocharitetum morsus-ranae* van Langendonck 1935; **Ph**: *Phragmition* W. Koch 1926; **Ma**: *Magnocarition* W. Koch 1926; **Po**: *Potamogetonion* (W. Koch 1926) Oberd. 1957; **Ny**: *Nymphaeion* W. Koch 1926; **Ho**: *Hottonion* Segal 1964.

Abbreviations used for the types of water body – **ORB**: old river beds; **PD**: peat diggings; **FP**: fish-ponds; **L**: lakes; **DD**: drainage ditches; **R**: rivers; **CP**: clay pits.

4. RESULTS

4.1. Structure and representativeness of the set of data under study

As was mentioned above (Section 3.3), a special sampling procedure was adopted in order to obtain a representative set of relevés. However, in the course of the study, it became clear that this approach did not completely secure the representativeness of the entire data set. Detailed investigations were then undertaken to estimate the representativeness of this set with regard to some selected characteristics important for further analyses, namely: (1) type of water body, (2) type of aquatic and helophytic vegetation or vegetation type, (3) number of pleustonic species per relevé represented by the variable k , where $k = 1, 2, \dots, n$ species per relevé, and (4) the water pH.

Characteristics (1) and (2) – These were used to select the relevant subsets of relevés from the whole set, as shown in Fig. 1. This selection was necessary because the characteristics in question were not always recorded, e.g. sometimes the water body type had not been precisely determined or an individual relevé had not been assigned to a definite plant association. Such relevés, therefore, had to be excluded from the set investigated.

For characteristic (1), all relevés had been assigned to one of the following types of water body: old river beds, peat diggings, fish-ponds, lakes, drainage ditches, clay pits or rivers. Thus subset B, consisting of 1570 relevés, was formed. It comprised 81 per cent of the entire set of relevés.

Subsequently, to satisfy – the requirements of characteristic (2), subset C, consisting of 1255 relevés assigned to definite associations, was selected from subset B. This subset did not include relevés classed into the association *Myriophyllo-Nupharetum* W. Koch 1926. Findings by Tomaszewicz (1977b) showed that phytocoenoses assigned until recently to this syntaxon represent different associations belonging to either of the alliances *Nymphaeion* W. Koch 1926 or *Potamogetonion* (W. Koch 1926) Oberd. 1957. Also relevés representing phytocoenoses assigned to the association *Scirpo-Phragmitetum* W. Koch 1926 were excluded from the subset because this syntaxon is a collective unit. Among others, it may contain stands of the associations *Eleocharitetum palustris* Schenikow 1919, *Sagittario-Sparganietum* R. Tx. 1953 and *Hippuridetum vulgaris* Pass. 1955 classed, at present, into either of the alliances *Phragmition* W. Koch 1926 (Matuszkiewicz 1981) or *Eleocharido-Sagittarion* Pass. 1964 (Tomaszewicz 1973, 1980).

The subsets of relevés representing autonomous synusiae and those comprising relevés representing different aquatic and helophytic plant associations – phytocoenoses of which are inhabited by non-autonomous synusiae – with respect to the different types of water body under consideration are shown in Fig. 2.

The whole collection of relevés cannot be considered as representative with respect to both the characteristics in question. As stated before (section 3.3), the Braun-Blanquet method of making relevés is subjective. Accordingly, a phytosociologist selects not only stands in which he makes relevés but also types of habitat, e.g. he tends to limit his investigations only to ponds, old river beds or lakes, etc. Hence the proportions of the different phytocoenoses, as well as the types of water body found in the collection of relevés, do not reflect the proportions actually occurring in the area investigated. The sampling procedure applied could not therefore overcome this difficulty. It could only supply, to some extent, additional information which had been omitted during the creation of the relevés among the pleustonic stands. In our case, this information concerned the aquatic and helophytic phytocoenoses as well as the water body types inhabited by lemnids. By incorporating it, more reliable ecological scales of the pleustonic species under consideration, as well as their assemblages, could be recorded.

The sampling procedure used produced a subset of non-autonomous pleustonic synusiae to the exclusion of the autonomous one. As has been mentioned earlier, the subset containing the autonomous pleustonic synusiae cannot be treated as a random and representative sample because the recorded stands were not chosen at random. The reverse happens with respect to non-autonomous synusiae. In this case, a phytosociologist pays attention above all to the species characteristic of aquatic and helophytic phytocoenoses. As a result of this procedure, the pleustonic species found in the relevés made in these phytocoenoses are likely to constitute haphazard elements so the assemblages of them recorded in a set of such relevés may be representative of the assemblages occurring in nature.

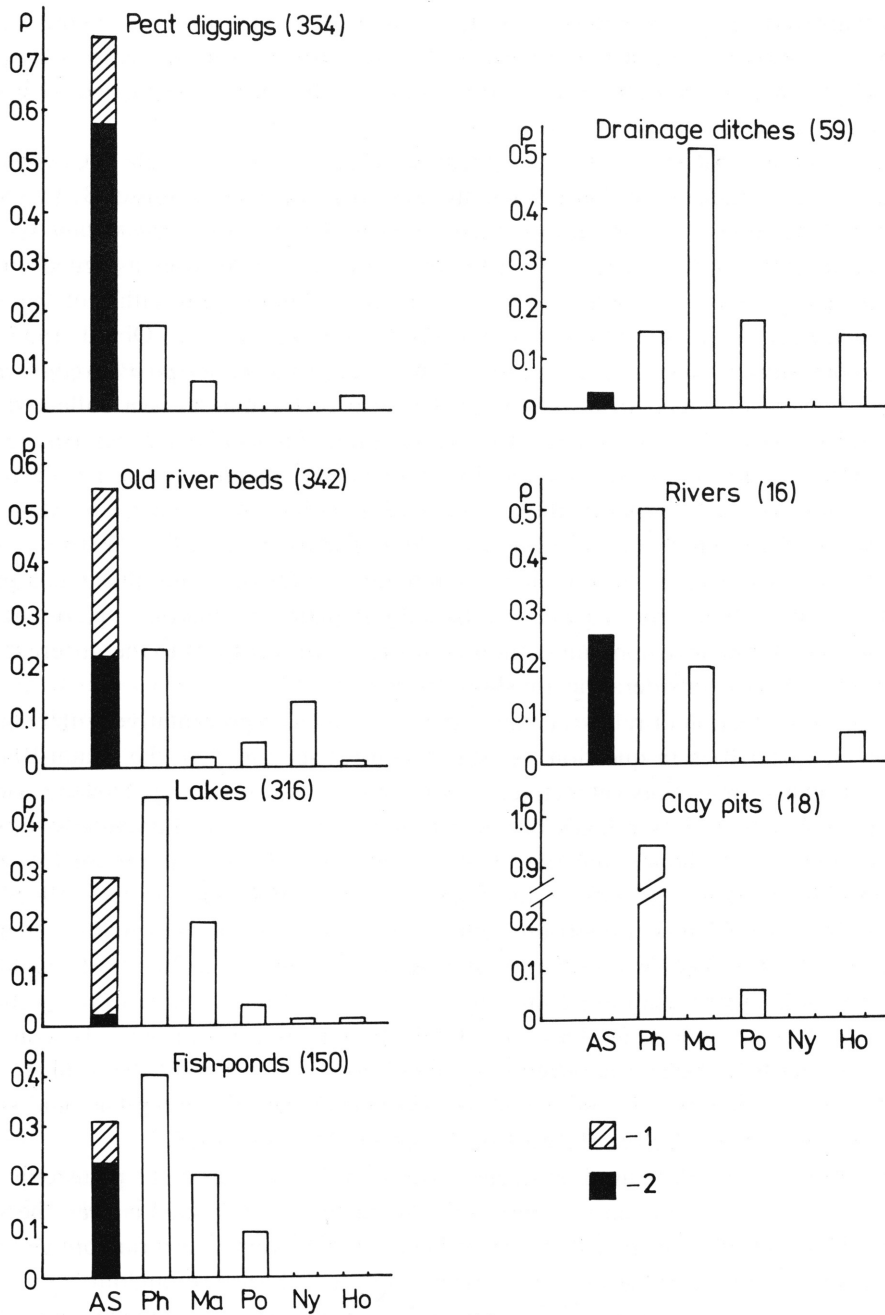

Fig. 2. Number of relevés representing autonomous (AS) and non-autonomous pleustonic synusiae with respect to different types of water body (subset C; Fig. 1). *Ph*, *Ma*, *Po*, *Ny* and *Ho* represent the alliances of aquatic and helophytic plant associations, the phytocoenoses of which are inhabited by non-autonomous pleustonic synusiae. The numbers of relevés analyzed are given in parentheses. Autonomous synusiae are composed of (1) relevés representing the association *Hydrocharitetum morsus-ranae* and (2) relevés representing associations of the alliance *Lemnion minoris*. p = proportion of relevés expressed as a decimal.

Characteristic (3) – The numbers of pleustonic species per relevé with respect to the autonomous pleustonic synusiae (subset D; Fig. 1) as well as to the aquatic and helophytic phytocoenoses belonging to different vegetation alliances (subsets *Phragmition*, *Magnocaricion*, *Potamogetonion*, *Nymphaeion* and *Hottonion* derived from subset E, see Fig. 1) are shown in Fig. 3. Already it is easy to recognize at first sight the following three kinds of frequency distribution for the species number per relevé, namely: (1) the symmetrical distribution (the subset of autonomous pleustonic synusiae), (2) the positively skew distribution (subset *Phragmition*, *Magnocaricion* and *Potamogetonion*), and (3) the approximately uniform distribution (subset *Nymphaeion* and *Hottonion*).

When the autonomous synusiae are considered (the first case), the large sample (595 relevés) may suggest that the frequency distribution of the number of pleustonic species per relevé reflects the actual frequency pattern in pleustonic communities, i.e. that the three- and four-species phytocoenoses are the most frequent whereas the one- and six-species phytocoenoses are the most rare (Fig. 3). However, this is not true. Let us consider the subset embracing the autonomous pleustonic synusiae (subset D) in detail. As was mentioned earlier, this subset contains relevés pertaining to the alliance *Lemnon minoris* as well as to the association *Hydrocharitetum morsus-ranae*. Relevés assigned to this subset are usually made in well-developed, multi-species stands and seldom or never in two-species ones. In the latter case, mainly the combination *Lemna minor*-*L. trisulca* is recorded and such relevés are classified as belonging to the association *L. minor*-*L. trisulca* R. Tx. 1955. One-species autonomous pleustonic assemblages are omitted in the course of phytosociological study and therefore they are not represented in the subset of relevés in question (see Fig. 4). For the association *Hydrocharitetum morsus-ranae* the situation is different. There are two species characteristic of this association: *Hydrocharis morsus-ranae* and *Stratiotes aloides* L. (Matuszkiewicz 1981). If only these two species occur in a relevé then, with regard to *H. morsus-ranae*, this relevé is classed as a one-species stand. Hence, one-species relevés are present in the subset under consideration (see Fig. 4) but *H. morsus-ranae* is the only pleustonic species occurring in this category of the variable *k*.

As may be concluded from the above, the symmetrical frequency distribution of the number of pleustonic species per relevé found in subset D, embracing autonomous pleustonic synusiae, results from the method of making relevés mentioned earlier, i.e. from recording multispecies stands and neglecting those with a small number of pleustonic species, especially with one species. In this way a strongly biased sample of relevés is obtained which can in no way be regarded as representative of the statistical population. The method of taking into account all relevés in which at least one pleustonic species is present, applied in this study, fails in the case of the subset of autonomous pleustonic synusiae because of the absence of details of relevant relevés in phytosociological papers for the reasons mentioned above. It was therefore impossible to improve the subset of relevés in question and the only solution, not feasible in this study, was to make new relevés in autonomous pleustonic synusiae, following the method mentioned above.

In the second case, as can be seen from Fig. 3, the frequency distributions found in the subsets *Phragmition*, *Magnocaricion* and *Potamogetonion* are very similar. It seems that

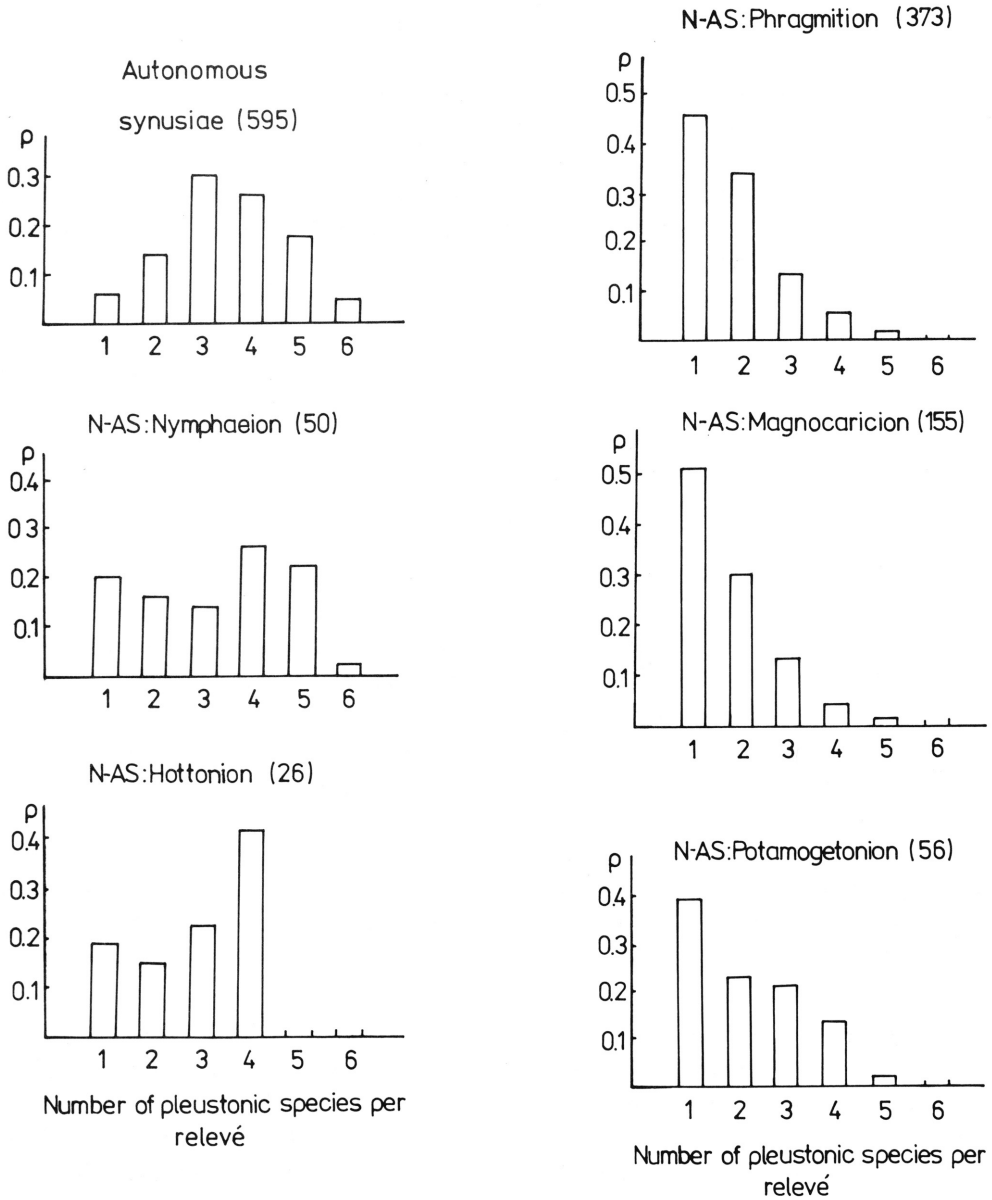

Fig. 3. Frequency distribution of k -species combinations found in autonomous (AS) and non-autonomous (N-AS) pleustonic synusiae, coded as subsets D and E, respectively (Fig. 1). *Ph*, *Ma*, *Po*, *Ny* and *Ho* represent the subsets of relevés belonging to subset E. The numbers of relevés analyzed are given in parentheses. p = proportion of relevés expressed as a decimal.

this frequency pattern is a consequence of the sampling method used in this study, chosen in order to collect an unbiased set of data.

For the subset *Nymphaeion* (Fig. 3), the uniform frequency distribution can be explained by the structure of the subset. Out of the 50 relevés considered more than 90 per

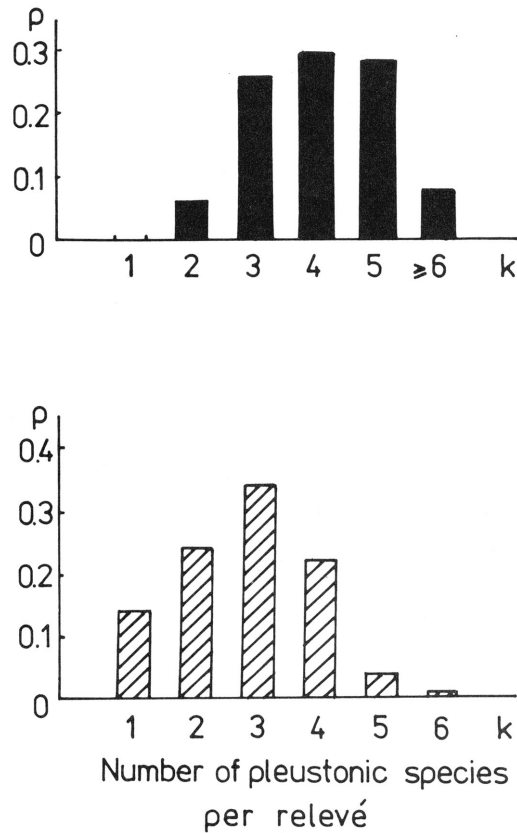

Fig. 4. Frequency distribution of k -species combinations found in relevés representing phytocoenoses of the alliance *Lemnion minoris* (black bars; 326 relevés) and in relevés representing the association *Hydrocharitetum morsus-ranae* (shaded bars; 269 relevés), coded as subsets F and G, respectively (Fig. 1). p = proportion of relevés expressed as a decimal.

cent were made by Piórecki (1975) in stands with *Trapa natans* L. occurring in old river beds in the Sandomierz Basin, Poland. As is seen from the above, the great majority of the data in the sample belongs only to one plant association. Further, these relevés were made by the same author in one type of water body. Hence, this subset of relevés cannot be treated as a representative sample of (1) either the alliance *Nymphaeion*, or (2) the water body type inhabited by phytocoenoses belonging to the alliance and, especially, (3) of the variable k . This may explain the difference between the frequency distribution of the pleustonic species number per relevé found in the subset *Nymphaeion* and the positively skew frequency patterns described in the cases of the subsets *Phragmition*, *Magnocaricion* and *Potamogetonion*.

We can reach the same conclusion for the subset *Hottonion* (Fig. 3). 64 per cent of all the relevés used originate from papers by Kępczyński (1960, 1965) while 80 per cent of them were made in drainage ditches and peat diggings. The small size of the sample ($N = 26$ relevés) may also have considerable influence on the frequency distribution

which is so different in shape from the frequency pattern revealed in helophytic phytocoenoses. It may be supposed that in representative samples of the alliances *Nymphaeion* and *Hottonion*, with respect to the phytocoenoses and water body types sampled, the frequency distribution of the number of pleustonic species per relevé would also have been positively skew as was the case with helophytic phytocoenoses.

Similar frequency patterns for the number of pleustonic species per relevé (as found in the subsets of relevés representing autonomous synusiae, as well as in those representing associations belonging to the alliances *Phragmition*, *Magnocaricion* and *Potamogetonion*, Figs 3 & 4) are also seen if the phytocoenoses of autonomous synusiae, as well as the aquatic and helophytic associations, are considered with respect to the different types of water body. This result is summarized in Fig. 5. In spite of some differences among individual frequency distributions found in the subsets of autonomous and non-autonomous synusiae, respectively, one general regularity seems to be evident: the frequency pattern for the number of pleustonic species per relevé is specific to the method of sampling (Braun-Blanquet's and that used in this study), i.e. the pattern is symmetrical in the first case (the subset of autonomous synusiae) and positively skew in the second (the subset of non-autonomous synusiae).

These frequency patterns, so unlike and repeated in different and independent subsets of relevés representing autonomous and non-autonomous synusiae, respectively, suggest, in the context of the study, the following conclusions.

The constant occurrence of the symmetrical frequency pattern in the subsets of the autonomous synusiae suggests that these subsets have been derived from the same statistical population or from identical statistical populations with respect to the number of pleustonic species per relevé. However, for the reasons mentioned earlier with regard to the subjective method of sampling, the subsets in question can only be treated as pseudo-homogenous and therefore cannot be considered representative of the statistical population with respect to the variable considered. This constant occurrence merely provides evidence for the assertion that there is no significant difference between phytosociologists when the Braun-Blanquet method of making relevés is used.

On the other hand, for the reason discussed earlier, the constant occurrence of the positively skew frequency pattern in subsets obtained by means of the objective sampling procedure used in this study suggests the following conclusions:

(1) it seems very probable that the positively skew frequency pattern for the number of pleustonic species per relevé represents a pattern which actually exists in the field;

(2) following this assumption it may be concluded that the frequency of occurrence of k -species non-autonomous assemblages occurring within phytocoenoses of aquatic and helophytic associations decreases as the number of pleustonic species per relevé increases;

(3) a consequence of the above is that the subset consisting of relevés representing non-autonomous assemblages may probably be regarded as representative of the occurrence of pleustonic species in the field.

Characteristic (4) – The subset of 726 relevés in which pH values were accurately recorded has been selected from the whole collection of relevés (subset pH₀; Fig. 1). The

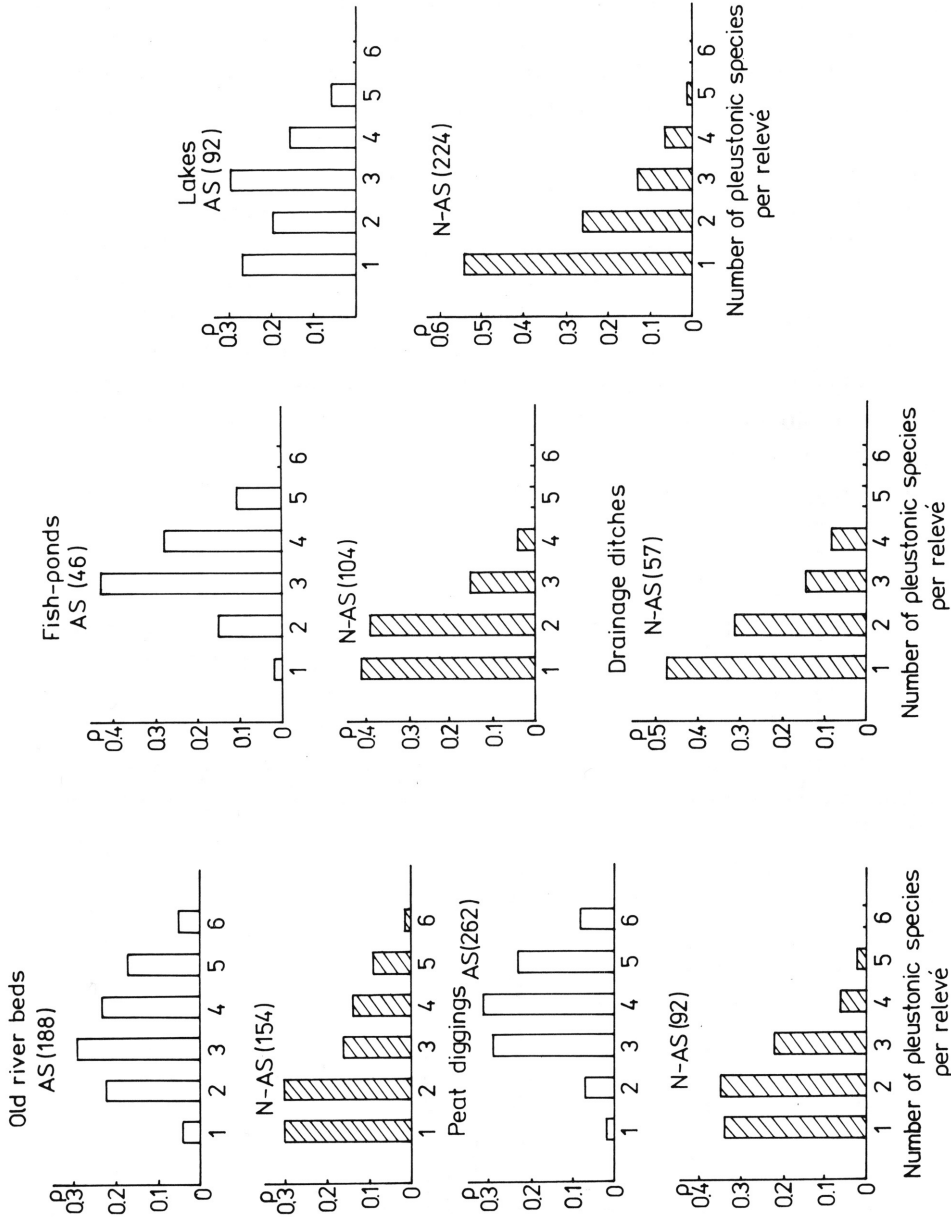

Fig. 5. Frequency distribution of *k*-species combinations found in autonomous (AS) and non-autonomous (N-AS) pleustonic synusiae, with respect to different types of water body, calculated from subset C (Fig. 1). The numbers of relevés analyzed are given in parentheses. *p* = proportion of relevés expressed as a decimal.

frequency distribution of these pH values appears in Fig. 6 which shows that some values of the pH, occurring at regular intervals along the x -axis, appear more frequently than others. These values are 6.0, 6.5, 7.0, 7.5, 8.0, 8.5 and 9. The only reasonable explanation of this frequency distribution is that it must be the result of rounding up pH values to those listed above. The effect of this practice becomes clearer when the frequency distribution of the pH values is considered with respect to a particular type of water body (Fig. 7); it is then evident from this figure that some authors in particular are responsible for this unusual pattern.

The frequency distributions of the pH values with respect to the subsets of relevés representing autonomous phytocoenoses and non-autonomous assemblages are shown in Fig. 6 (subsets AS and N-AS, respectively). There are some differences between these distributions but they are not as marked as in the case of characteristic (3) (=number of species per relevé). On the other hand, the phenomenon of certain pH values occurring more frequently than others is observed also in both frequency distributions (Fig. 6). To remove these unintentional consequences of rounding up pH values some attempts were made to divide the values of water pH sampled into appropriate data categories. The final

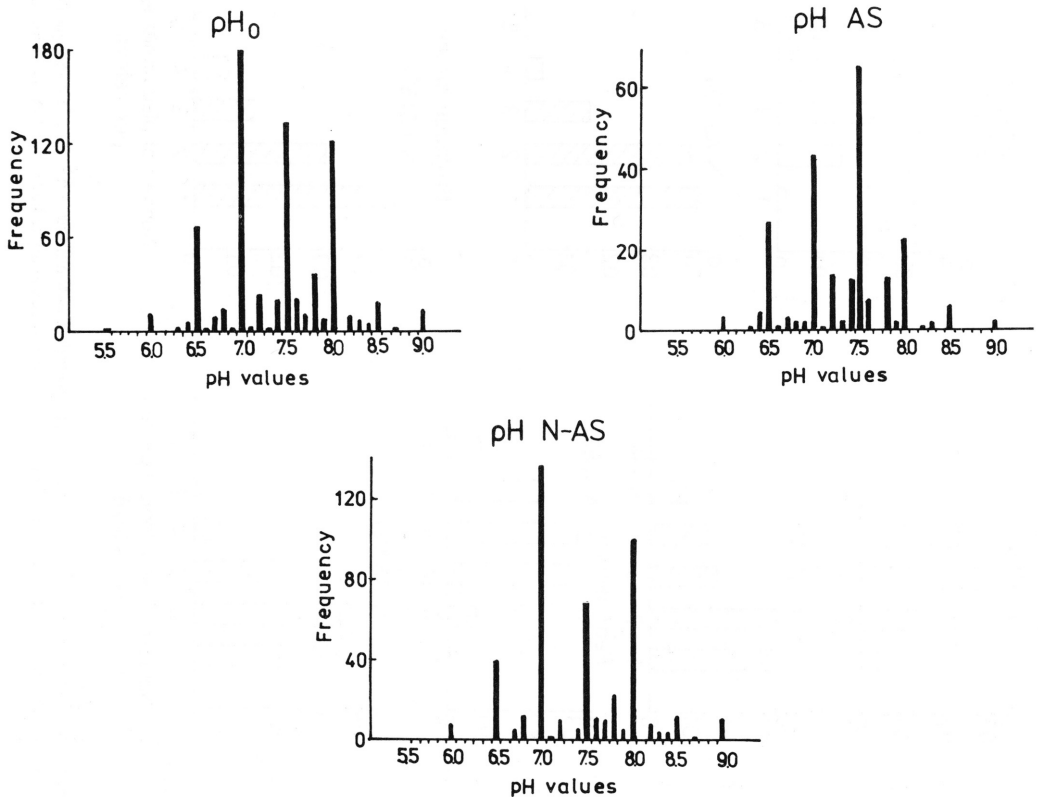

Fig. 6. Frequency distributions of water pH values, calculated for 726 relevés (subset pH₀; Fig. 1) as well as for the subsets of autonomous (pH AS; 242 relevés) and non-autonomous synusiae (pH N-AS; 484 relevés), selected from subset pH₀.

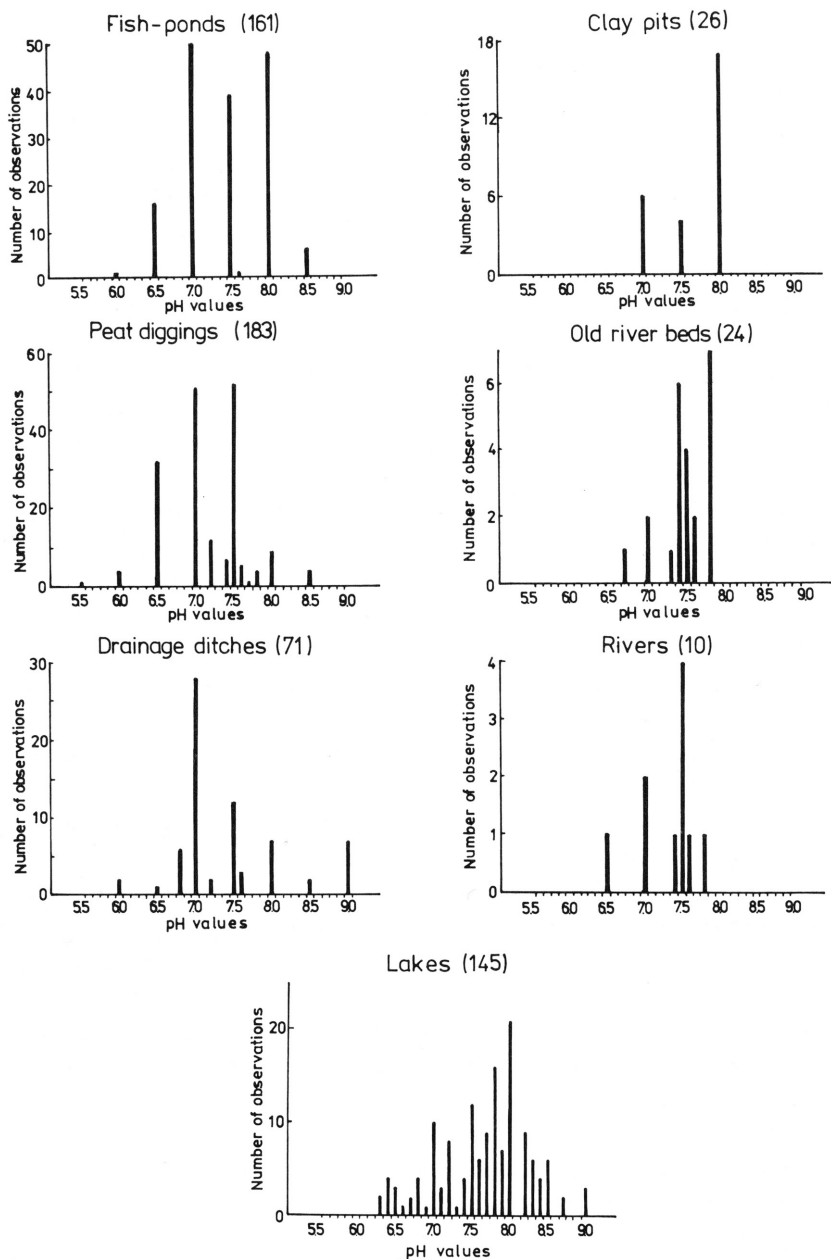

Fig. 7. Frequency distributions of water pH values with respect to different types of water body. The data shown (selected from subset pH₁; Fig. 1) were extracted from the following papers: *fish-ponds* – Kępczyński (1965: 2 relevés), Podbielkowski (1968: 157), Wołek (1974a: 2); *peat diggings* – Kępczyński (1960: 15, 1965: 96), Podbielkowski (1960: 70), Tomaszewicz (1977a: 1); *drainage ditches* – Kępczyński (1960: 2, 1965: 11), Podbielkowski (1967: 57); *clay pits* – Podbielkowski (1969: 27); *old river beds* – Kępczyński and Fabiszak (1972: 12), Wołek (1974a: 11); *rivers* – Kępczyński (1965: 9), Wołek (1974a: 1); *lakes* – Dąmbska (1961: 31), Dąmbska and Kraska (1976: 2), Dziedzic and Asztemborski (1969: 11), Gołdyn (1975: 25), Kępczyński (1960: 38, 1965: 21), Kępczyński and Zieliński (1974: 1), Polakowski and Dziedzic (1972: 15). The numbers of relevés analyzed are given in parentheses.

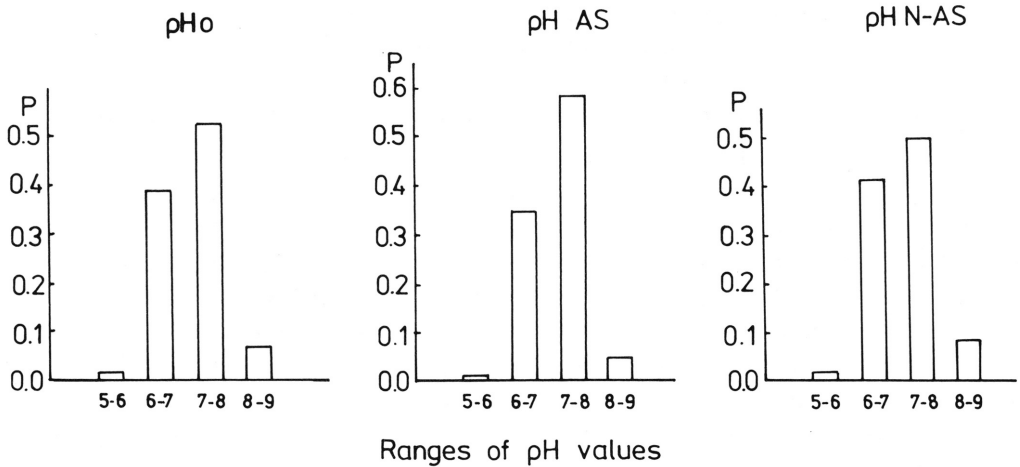

Fig. 8. Frequency distributions of water pH values with respect to different pH categories, calculated for subset pH₀ (726 relevés; Fig. 1) and for the subsets of autonomous (pH AS; 242 relevés) and non-autonomous (pH N-AS; 484 relevés) synusiae, selected from subset pH₀. p = proportion of relevés expressed as a decimal.

result of these attempts is presented in Fig. 8 which shows that the same frequency pattern is revealed independently of the subset considered (subset pH AS or subset pH N-AS). It seems very probable that this outcome results from the fact that relevés were made in stands selected from a floristic point of view and not from consideration of the water pH. As a consequence of this procedure the pH values recorded in the relevés are likely to constitute haphazard elements and, therefore, their sample may be regarded as representative. In this respect the situation discussed here is the same as in the case of characteristic (3) (=number of pleustonic species per relevé) considered with regard to autonomous and non-autonomous synusiae (see above, this section).

The findings presented here relating to the four selected characteristics, i.e. type of water body, type of vegetation, number of species per relevé and water pH, are of fundamental significance for the interpretation of the outcomes of analyses presented in the subsequent sections of this paper. As the method of statistical inference is used, irrespective of whether statistical tests or mere statistical description are applied, the results obtained can be applied to either the sample analyzed (subsets of autonomous synusiae) or generalized to the statistical population studied (subsets of non-autonomous synusiae).

As has been shown, some subsets of data may be treated as representative of the statistical population with respect to one variable but not in relation to other variables. These subsets cannot therefore be considered random samples in the strict sense; in the case of a true random sample we can consider this sample as representative with respect to all possible characteristics observed in the statistical population sampled. For this reason, if necessary, the following procedure was always observed during analyses carried out: all differences found in the frequency distributions of the variables under consideration were at first interpreted with reference to the structure of the subset analyzed and subsequently (if necessary) with the aid of the ecology of the species in question.

4.2. Relationships between pleustonic species assemblages and some ecological factors

4.2.1. The influence of water pH on the number of pleustonic species per relevé

The proportions of the relevés representing individual combinations of pleustonic species with regard to different pH ranges are shown in Table 1. As may be seen from this table, the majority of data come from water whose pH ranges from 6.1 to 8.0. From these data 40 per cent of the relevés fall into the acid water category ($\text{pH} \leq 7.0$) while 60 per cent are alkaline ($\text{pH} > 7.0$). In order to examine whether the sampled proportions in different k -species combinations are the same for each water category (see Table 2), the null hypothesis of no difference was tested by means of the chi-square test of homogeneity. Six- and seven-species combinations were not taken into account because of the small number of data. The result obtained ($\chi^2 = 11.485$, $\text{df} = 4$, $\chi^2_{.05} = 9.49$) shows that there are significant differences among the proportions compared. Significant surpluses (+) and deficiencies (–) in the observed fractions of relevés as compared with the expected ones were found in the case of 3- and 4-species combinations (Table 2). These combinations were then excluded from the subset analyzed and the remaining data, consisting of 1-, 2- and 5-species combinations, were tested once more. This time, the result obtained ($\chi^2 = 0.309$, $\text{df} = 2$, $\chi^2_{.05} = 5.99$) permits us to accept the null hypothesis of no significant difference among the proportions compared. This may suggest that in the case of 1-, 2- and 5-species combinations 59 per cent of the observations pertain to water with $\text{pH} > 7.0$ and 41 per cent to water with $\text{pH} \leq 7.0$. As may be seen from Table 2, the proportions in question are nearly the same for 3-species combinations, but in the case of 4-species ones 70 per cent of relevés have water with $\text{pH} > 7.0$. This result, so different from the outcome obtained for the 1-, 2- and 5-species combinations, suggests that the 3- and 4-species combinations are not homogeneous with the 1-, 2- and 5-species ones. What causes this heterogeneity? How can this result be explained? Is it possible that these 3- and 4-species combinations are determined by different mechanisms related to water pH? Before discussing this supposition in detail and drawing definite conclusions, some remarks on the structure of the subset considered are in order.

When analyzing the floristic composition of the species combinations in question (Table 1) one can see that in the case of 1-species combinations, 92 per cent of the observations concern only 3 from among the 7 combinations observed, i.e. *Lemna minor*, *L. trisulca* and *Hydrocharis morsus-ranae*, and that, in this group of relevés, 62 per cent of the observations concern only *L. minor*. As regards the 2-species combinations, 92 per cent of the observations concern 5 from among the 13 combinations observed, namely *Lm-Ltr*, *Lm-Sp*, *Lm-H*, *Ltr-Sp* and *Ltr-H*. With respect to the 3-species combinations, 80 per cent of the observations concern only 3 from among the 14 combinations observed, i.e. *Lm-Ltr-Sp*, *Lm-Ltr-H* and *Lm-Sp-H*, and in the case of the 4-species combinations, 73 per cent of the observations concern only 2 from among the 14 combinations observed, i.e. *Lm-Ltr-Sp-H* and *Lm-Ltr-Sp-W*. The combinations listed above consist mainly of *L. minor*, *L. trisulca*, *Spirodela polyrhiza* and *H. morsus-ranae*. As can be seen from the above, *Wolffia arrhiza* was only found in one from among all the combinations in ques-

Table 1. Numbers of relevés representing different pleustonic species combinations in different ranges of water pH (subset pH₀; Fig. 1).

Combinations	pH				No. of relevés
	5.1–6.0	6.1–7.0	7.1–8.0	8.1–9.0	
<i>Lm</i>	4	61	60	8	133
<i>Ltr</i>		7	25	2	34
<i>Sp</i>		2	8		10
<i>H</i>		12	12	14	38
<i>Rfl</i>	1		3		4
<i>Ric</i>		1			1
<i>Sal</i>		1	1		2
Total	5	84	109	24	222
<i>Lm-Ltr</i>		24	28	8	60
<i>Lm-Sp</i>		17	42	2	61
<i>Lm-H</i>	1	18	13	4	36
<i>Lm-Sal</i>		1		1	2
<i>Lm-Rfl</i>		1			1
<i>Lm-Ric</i>	1				1
<i>Ltr-Sp</i>		7	4		11
<i>Ltr-H</i>		5	7		12
<i>Ltr-Sal</i>			1		1
<i>Ltr-Ric</i>			1		1
<i>Sp-H</i>		4	1		5
<i>Sp-Sal</i>			2		2
<i>Ric-Rfl</i>			2		2
Total	2	77	101	15	195
<i>Lm-Ltr-Sp</i>		23	24	1	48
<i>Lm-Ltr-H</i>		22	15	6	43
<i>Lm-Ltr-Rfl</i>		1	3		4
<i>Lm-Ltr-Ric</i>		1			1
<i>Lm-Sp-H</i>	1	18	12	1	32
<i>Lm-Sp-W</i>		1			1
<i>Lm-Sp-Sal</i>			3	3	6
<i>Lm-Sp-Rfl</i>	2	3	2		7
<i>Lm-Sp-Ric</i>		1	2		3
<i>Lm-H-Sal</i>		1			1
<i>Lm-H-Ric</i>			1		1
<i>Lm-Sal-Rfl</i>		1			1
<i>Ltr-Sp-H</i>		3	1		4
<i>Ltr-H-Sal</i>			2		2
Total	3	75	65	11	154
<i>Lm-Ltr-Sp-H</i>		16	37		53
<i>Lm-Ltr-Sp-W</i>		6	16		22
<i>Lm-Ltr-Sp-Lg</i>			1	1	2
<i>Lm-Ltr-Sp-Sal</i>			1		1
<i>Lm-Ltr-Sp-Rfl</i>			7		7
<i>Lm-Ltr-H-Sal</i>			3		3

(cont.)

Table 1. Continued.

Combinations	pH				No. of relevés
	5.1–6.0	6.1–7.0	7.1–8.0	8.1–9.0	
<i>Lm-Ltr-H-Rfl</i>		2	1		3
<i>Lm-Ltr-W-Lg</i>			1		1
<i>Lm-Ltr-Rfl-Ric</i>			1		1
<i>Lm-Sp-H-W</i>			1		1
<i>Lm-Sp-H-Sal</i>		2	1		3
<i>Lm-Sp-H-Rfl</i>		3	1		4
<i>Lm-Sp-W-Ric</i>		1			1
<i>Lm-Sp-Rfl-Ric</i>		1			1
Total		31	71	1	103
<i>Lm-Ltr-Sp-H-W</i>		2	5		7
<i>Lm-Ltr-Sp-H-Lg</i>			1		1
<i>Lm-Ltr-Sp-H-Sal</i>		3	9		12
<i>Lm-Ltr-Sp-H-Rfl</i>		2	1		3
<i>Lm-Ltr-Sp-W-Lg</i>		1	8		9
<i>Lm-Ltr-Sp-W-Rfl</i>			1		1
<i>Lm-Ltr-Sp-W-Ric</i>		2			2
<i>Lm-Ltr-H-Rfl-Ric</i>	1	1			2
<i>Lm-Sp-H-W-Ric</i>		2			2
Total	1	13	25		39
<i>Lm-Ltr-Sp-H-W-Lg</i>			5		5
<i>Lm-Ltr-Sp-H-Lg-Sal</i>			2		2
<i>Lm-Ltr-Sp-W-Lg-Rfl</i>			4		4
Total			11		11
<i>Lm-Ltr-Sp-H-Lg-Sal-Ric</i>			2		2
Total			2		2
Total	11	280	384	51	726
Proportion	0.015	0.386	0.529	0.070	1.000

tion. It seems therefore that the different results obtained in the case of the 3- and 4-species combinations might be explained by analyzing the responses of these main component species to the pH values of the water. Let us consider this problem now.

The frequencies of occurrence of the species encountered in acid and alkaline waters were estimated on the basis of a subset of 726 relevés (Table 3). The null hypothesis that the observed proportions of the four species in question are the same whatever the water category was tested. The result obtained ($\chi^2 = 6.96$, $df = 3$, $\chi^2_{.05} = 7.82$) enables us to accept the null hypothesis and to conclude that the proportions considered are the same. Therefore the suggestion is that the pH values of the water do not influence the occurrence of these species and that the proportions of observations falling into the two categories of water, acid and alkaline, amount to 40 and 60 per cent, respectively. It may therefore be assumed that there are no differences among the species considered with regard to their responses to acid and alkaline water.

Table 2. The frequencies of occurrence k -species combinations in two alternative water categories, acid ($\text{pH} \leq 7.0$) and alkaline ($\text{pH} > 7.0$). The null hypothesis stating that the probability of being in a particular water category is the same for all k -species combinations was tested by means of the chi-square test of homogeneity. Data originate from subset pH_0 (Fig. 1).

Combinations	$\text{pH} \leq 7.0$	$\text{pH} > 7.0$	No. of relevés	χ^2
1-species	89	133	222	0.048
2-species	79	116	195	0.008
3-species	(+78)	(-76)	154	6.182
4-species	(-31)	(+72)	103	4.864
5-species	14	25	39	0.383
Total	291	422	713	11.485*
(%)	40.8	59.2	100.0	×

* $P(\text{df}=4) < 0.05$

Table 3. The percentage frequencies of occurrence of *Lemna minor* L. (**L**), *L. trisulca* L. (**Ltr**), *Spirodela polyrrhiza* (L.) Schleid. (**S**) and *Hydrocharis morsus-ranae* L. (**H**) in different ranges of water pH. The numbers of observations are given in parentheses. Data originate from subset pH_0 (Fig. 1).

Species	pH				$\text{pH} \leq 7.0$	$\text{pH} > 7.0$
	5.1–6.0	6.1–7.0	7.1–8.0	8.1–9.0		
<i>H</i> (277)	1.0	42.0	48.0	9.0	43.0	57.0
<i>Lm</i> (597)	2.0	40.0	52.0	6.0	42.0	58.0
<i>Sp</i> (334)	1.0	36.0	61.0	2.0	37.0	63.0
<i>Ltr</i> (363)	0.3	35.0	60.0	4.7	35.0	65.0
Total (%)	×	×	×	×	39.5	60.5

Table 4. The percentage frequencies of occurrence of *Lemna gibba* L. (**L**), *Wolffia arrhiza* (L.) Wimm. (**W**), *Salvinia natans* (L.) All. (**Sal**), *Ricciocarpos natans* (L.) Corda (**Ricc**) and *Riccia fluitans* L. (**Rfl**) in different ranges of water pH. The numbers of observations are given in parentheses. Data originate from subset pH_0 (Fig. 1).

Species	pH				$\text{pH} \leq 7.0$	$\text{pH} > 7.0$
	5.1–6.0	6.1–7.0	7.1–8.0	8.1–9.0		
<i>Ric</i> (21)	9.0	48.0	43.0		57.0	43.0
<i>Rfl</i> (46)	8.0	33.0	59.0		41.0	59.0
<i>W</i> (56)		27.0	73.0		27.0	73.0
<i>Sal</i> (40)		22.0	68.0	10.0	22.0	78.0
<i>Lg</i> (26)		4.0	96.0		4.0	96.0

In this respect, different occurrence patterns were revealed in the remaining pleustonic species (Table 4). Inspection of this table suggests that three of the considered species, *Wolffia arrhiza*, *Salvinia natans* and *Lemna gibba*, are more frequently found in alkaline water, with their observed proportions amounting to 73, 78 and 96 per cent, respectively. It seems also that *Ricciocarpos natans* prefers acid water, while *Riccia fluitans* has the same frequency pattern as the four main pleustonic species considered

above (Table 3). These conclusions should, however, be examined by using a larger data sample than has been done here, especially in the case of *R. natans* and *L. gibba*.

The outcome obtained for the 1-, 2- and 5-species combinations can be better understood if we take into account the results presented above and the fact that the combinations in question contain one or more of *Lemna minor*, *L. trisulca*, *Spirodela polyrhiza* and *Hydrocharis morsus-ranae*. In this situation, however, in the case of 3- and 4-species assemblages, containing the same species, the proportions for the two categories of water should be identical with those of the 1-, 2- and 5-species combinations. The different results obtained in this regard are probably caused by the fact that the whole collection of relevés, from which the pH subset was selected, is not representative regarding water body type (see section 4.1). It is reasonable to suppose that the subsets of relevés representing the 3- and 4-species combinations were not homogeneous with those comprising the 1-, 2- and 5-species ones in relation to water body type. Before drawing definite conclusions this supposition should therefore be examined.

At first, with the help of subset pH₁ (see Fig. 1), the null hypothesis that the sampled proportions in the seven types of water body are the same for acid and alkaline water was tested. The result of this investigation is shown in Table 5 and, as can be seen, these proportions differ considerably. This finding suggests that subset pH₁ ought to be treated as a heterogeneous sample with respect to the different water body types and therefore the relationship between the occurrence of pleustonic species and water pH should be tested separately for each water body type. By means of the chi-square test of homogeneity, two null hypotheses were tested. The first was that the probability of being in a particular water pH category was the same for all water body types. This hypothesis was tested separately for each class of *k*-species combinations. The second one was that the probability of being in a particular water pH category was the same for all *k*-species combinations. This hypothesis was tested separately for each water body type. The results obtained are shown in Tables 6 and 7, respectively. For the first hypothesis, the calculated statistic values are higher than the tabled ones in three cases out of four, and the differences are highly significant (Table 6). It may therefore be concluded that the proportions are not uniform among the water body types, i.e. they are heterogeneous. For the second hypothesis, in all cases except one, the calculated values were lower than the

Table 5. The proportions of relevés in the two alternative water categories, acid (pH ≤ 7.0) and alkaline (pH > 7.0), with respect to the different types of water body, calculated from subset pH₁ (Fig. 1).

Water body type	pH≤7.0	pH>7.0	No. of relevés
old river beds	0.125	0.875	24
lakes	0.186	0.814	145
clay pits	0.192	0.808	26
rivers	0.300	0.700	10
fish-ponds	0.416	0.584	161
peat diggings	0.486	0.514	183
drainage ditches	0.535	0.465	71
Total	×	×	620

tabled ones (Table 7). It is thus concluded that the proportions are uniform among the k -species combinations, i.e. they are homogeneous. The result obtained supports the suggestion that the proportions in question should be analyzed separately in different water body types.

The frequencies of occurrence of *Lemna minor*, *L. trisulca*, *Spirodela polyrhiza* and *Hydrocharis morsus-ranae* in acid and alkaline waters with respect to fish-ponds, lakes, peat diggings and drainage ditches are shown in Table 8. Statistical analysis was limited to the types of water body, selected from subset pH₁, where large subsets of data were available for use (subset pH₂; Fig. 1). The proportions observed were compared with the proportions expected under the null hypothesis characteristic for the individual types of water body (Table 8, see also Table 5). The null hypothesis that the probability of being in a particular water category is the same for all the pleustonic species considered was tested separately for each water body type (using the replicated goodness-of-fit of the chi-square test). In all cases but one there were no significant differences among the proportions compared (Table 8). The interpretation of this result is that the species considered reveal the same frequency occurrence patterns characteristic for a given water

Table 6. The proportions of relevés in the two alternative water categories, acid (pH ≤ 7.0) and alkaline (pH > 7.0), found in four types of water body, calculated separately for particular classes of k -species combinations (subset pH₂; Fig. 1). The null hypothesis stating that the probability of being in a particular water category is the same for all water body types was tested for each class of k -species combinations separately (the chi-square test of homogeneity).

Combinations	Water body type	pH≤7.0	pH>7.0	No. of relevés	χ^2
1-species	peat diggings	0.545	0.455	22	2.856
	fish-ponds	0.426	0.574	47	0.593
	lakes	0.121	0.879	58	15.595
	drainage ditches	0.575	0.425	40	7.175
	Total	0.371	0.629	167	26.219***
2-species	peat diggings	0.610	0.390	41	9.030
	fish-ponds	0.282	0.718	39	1.638
	lakes	0.273	0.727	33	1.664
	drainage ditches	0.278	0.722	18	0.823
	Total	0.382	0.618	131	13.155**
3-species	peat diggings	0.551	0.449	49	0.510
	fish-ponds	0.588	0.412	17	0.529
	lakes	0.208	0.792	24	8.167
	drainage ditches	0.875	0.125	8	4.500
	Total	0.500	0.500	98	13.706**
4-species	peat diggings	0.407	0.593	27	1.707
	fish-ponds	0.600	0.400	5	2.287
	lakes	0.087	0.913	23	4.715
	drainage ditches	0.333	0.667	3	0.023
	Total	0.293	0.707	58	4.738 ns

** $P(df=3) < 0.01$

*** $P(df=3) < 0.001$

ns = not significant at $\alpha = 0.05$

Table 7. The proportions of relevés in the two alternative water categories, acid ($\text{pH} \leq 7.0$) and alkaline ($\text{pH} > 7.0$) with respect to four classes of k -species combinations, calculated separately for each type of water body (subset pH_2 ; Fig. 1). The null hypothesis stating that the probability of being in a particular water category is the same for all k -species combinations was tested for each water body type, separately (the chi-square test of homogeneity).

Water body type	Combinations	$\text{pH} \leq 7.0$	$\text{pH} > 7.0$	No. of relevés	χ^2
peat diggings	1-species	0.545	0.455	22	0.003
	2-species	0.610	0.390	41	0.814
	3-species	0.551	0.449	49	0.026
	4-species	0.407	0.593	27	1.900
	Total	0.540	0.460	139	2.743 $_{ns}$
fish-ponds	1-species	0.426	0.574	47	0.064
	2-species	0.282	0.718	39	2.540
	3-species	0.588	0.412	17	2.307
	4-species	0.600	0.400	5	0.768
	Total	0.407	0.593	108	5.679 $_{ns}$
lakes	1-species	0.121	0.879	58	0.885
	2-species	0.273	0.727	33	2.673
	3-species	0.208	0.792	24	0.300
	4-species	0.087	0.913	23	1.049
	Total	0.167	0.833	138	4.907 $_{ns}$
drainage ditches	1-species	0.575	0.425	40	0.454
	2-species	0.278	0.722	18	4.291
	3-species	0.875	0.125	8	4.012
	4-species	0.333	0.667	3	0.428
	Total	0.522	0.478	69	9.185*

* $P(\text{df}=3) < 0.05$

$_{ns}$ = not significant at $\alpha = 0.05$

body type. It means then, that the observed differences in proportions were merely due to chance. As mentioned above, only in one case was a different result obtained when the frequency of occurrence of *H. morsus-ranae* in acid and alkaline waters in fish-ponds differed significantly from that expected. This disagreement probably does not reflect a real phenomenon. It is probably an anomaly because in other types of water body the species in question exhibits the same proportions as the remaining species (Table 8).

So far, the study of the relationship between water pH and the occurrence of pleustonic species has been based only on presence/absence data. It is to be expected, however, that closer relationships between the water pH and the species considered may be found when the cover-abundance values for a particular species are taken into account. This supposition may be verified using 1-species combinations. Multispecies combinations should be excluded from this investigation because, apart from the water pH, the abundance of a particular species may also be affected by, for example, competitive interaction with the other pleustonic species, if present. It is only in the case of *Lemna minor* that the data sample is sufficiently large. The proportions of 1-species relevés with *L. minor* in the two alternative water categories, ($\text{pH} \leq 7.0$) or alkaline ($\text{pH} > 7.0$), with

Table 8. The proportional frequencies of occurrence of *Lemma minor* L. (**Lm**), *L. trisulca* L. (**Ltr**), *Spirodela polyrhiza* (L.) Schleid. (**S**) and *Hydrocharis morsus-ranae* L. (**H**) in the two alternative water categories, acid ($\text{pH} \leq 7.0$) and alkaline ($\text{pH} > 7.0$), calculated separately for different types of water body. The numbers of relevés analyzed are given in parentheses. Data originate from subset pH_1 (Fig. 1). The null hypothesis stating that the probability of being in a particular water category is the same for all pleustonic species was tested for each water body type separately (using the replicated goodness-of-fit of the chi-square test). The proportions expected under H_0 were estimated and have appeared earlier in Table 5.

Water body type	Species (replicates)	f	$\text{pH} \leq 7.0$	$\text{pH} > 7.0$	df	χ^2
fish-ponds (161)	<i>Lm</i>	134	0.418	0.582	1	0.00ns
	<i>Ltr</i>	34	0.353	0.647	1	0.53ns
	<i>Sp</i>	85	0.400	0.600	1	0.09ns
	<i>H</i>	44	0.614	0.386	1	7.08**
	Total				4	7.70ns
	Pooled	297	0.434	0.566	1	0.40ns
	Heterogeneity				3	7.30ns
Proportions expected under H_0		161	0.416	0.584		
lakes (145)	<i>Lm</i>	102	0.196	0.804	1	0.06ns
	<i>Ltr</i>	69	0.188	0.812	1	0.00ns
	<i>Sp</i>	65	0.169	0.831	1	0.12ns
	<i>H</i>	75	0.240	0.760	1	1.41ns
	Total				4	1.59ns
	Pooled	311	0.199	0.801	1	0.36ns
	Heterogeneity				3	1.23ns
Proportions expected under H_0		145	0.186	0.814		
peat diggings (183)	<i>Lm</i>	141	0.504	0.496	1	0.18ns
	<i>Ltr</i>	123	0.431	0.569	1	1.50ns
	<i>Sp</i>	101	0.525	0.475	1	0.60ns
	<i>H</i>	76	0.553	0.447	1	1.37ns
	Total				4	3.65ns
	Pooled	441	0.496	0.504	1	0.20ns
	Heterogeneity				3	3.45ns
Proportions expected under H_0		183	0.486	0.514		
drainage ditches (71)	<i>Lm</i>	61	0.574	0.426	1	0.38ns
	<i>Ltr</i>	27	0.481	0.519	1	0.29ns
	<i>Sp</i>	12	0.750	0.250	1	2.26ns
	<i>H</i>	18	0.389	0.611	1	1.51ns
	Total				4	4.47ns
	Pooled	118	0.542	0.458	1	0.03ns
	Heterogeneity				3	4.44ns
Proportions expected under H_0		71	0.535	0.465		

** $P(\text{df}=1) < 0.01$

ns = not significant at $\alpha = 0.05$

respect to the Braun-Blanquet cover-abundance scale are shown in Table 9. The null hypothesis that the probability of *L. minor* being present in a particular water category is the same for all cover-abundance values was tested. The result obtained ($\chi^2 = 7.38$, $\text{df} = 3$,

Table 9. The proportions of 1-species relevés with *Lemma minor* L. in the two alternative water categories, acid ($\text{pH} \leq 7.0$) and alkaline ($\text{pH} > 7.0$), with respect to the Braun-Blanquet cover-abundance scale (C-AS), which was used to estimate the quantities of *L. minor*. Data originate from subset pH_0 (Fig. 1). The null hypothesis tested stated that the probability of *L. minor* occurring in a particular water category is the same for all the cover-abundance values considered (the chi-square test of homogeneity). (–) indicates a deficiency and (+) a surplus in the observed frequencies as compared with the expected ones.

C-AV	$\text{pH} \leq 7.0$	$\text{pH} > 7.0$	No. of relevés
+	0.396	0.604	58
1	0.500	0.500	32
2	0.478	0.522	23
≥ 3	(+)0.750	(–)0.250	20
Total	0.489	0.511	133

Table 10. The numbers of 1-species relevés containing *Lemma minor* L. in the two alternative water categories, acid ($\text{pH} \leq 7.0$) and alkaline ($\text{pH} > 7.0$), with respect to the Braun-Blanquet cover-abundance scale (C-AS), which was used for estimating the quantities of *L. minor* in different types of water body. Major discrepancies in the observed frequencies are indicated by the numbers appearing in heavy type.

Water body type	C-AV	$\text{pH} \leq 7.0$	$\text{pH} > 7.0$	No. of relevés
fish-ponds	+	6	9	15
	1	5	4	9
	2	3	4	7
	≥ 3	0	3	3
drainage ditches	+	6	3	9
	1	3	6	9
	2	2	3	5
	≥ 3	10	0	10
lakes	+	1	14	15
	1	0	3	3
	2	2	1	3
	≥ 3	0	0	0
peat diggings	+	1	1	2
	1	3	1	4
	2	1	0	1
	≥ 3	2	0	2
clay pits	+	1	2	3
	1	3	1	4
	2	0	2	2
	≥ 3	0	0	0
rivers	+	1	2	3
	1	1	0	1
	2	1	0	1
	≥ 3	0	0	0
remainder	+	7	4	11
	1	1	1	2
	2	2	2	4
	≥ 3	3	2	5

Table 11. Extreme values of the water pH at which the pleustonic species considered were found. Data originate from subset pH₀ (Fig. 1). The numbers of relevés analyzed are given in parentheses.

Species	pH range
<i>Lemna gibba</i> (26)	7.0–8.5
<i>Wolffia arrhiza</i> (56)	6.5–8.0
<i>Salvinia natans</i> (40)	6.5–8.5
<i>L. minor</i> (597)	6.0–9.0
<i>L. trisulca</i> (363)	6.0–9.0
<i>Spirodela polyrhiza</i> (334)	6.0–8.7
<i>Hydrocharis morsus-ranae</i> (277)	6.0–9.0
<i>Ricciocarpos natans</i> (21)	6.0–8.0
<i>Riccia fluitans</i> (46)	5.5–8.0

$\chi^2_{.05} = 7.82$) does not allow the rejection of the null hypothesis. It can be seen, however, that the statistic computed is only slightly lower than the critical value at the $\alpha = 0.05$ level of significance. It was found that frequencies corresponding to cover-abundance values ≥ 3 significantly influenced the chi-square statistic. A close examination of Table 10 shows that the numbers of observations from acid and alkaline water are roughly equal for all cover-abundance values (C-AV) in each type of water body. Major discrepancies in the observed frequencies were found only at two cover-abundance values, ≥ 3 (drainage ditches) and + (lakes). These differences in frequency (especially in the former case) increase the calculated value for the chi-square test statistic. It is reasonable to suppose, then, that these frequency irregularities are due only to chance and may be avoided by using a larger data sample.

The ranges of water pH values at which the pleustonic species under consideration have been found are shown in Table 11. The data presented in this table suggest that *Lemna minor*, *L. trisulca*, *Spirodela polyrhiza*, *Ricciocarpos natans* and *Hydrocharis morsus-ranae* are not encountered in waters with a pH below 6.0, *Wolffia arrhiza* and *Salvinia natans* in waters with a pH below 6.5 and *L. gibba* with a pH below 7.0. Only *Riccia fluitans* was found in waters with pH 5.5. Also the species would appear to tolerate different maximum pH values.

As the sample data indicate (Table 1), 91.6 per cent of the observations were from waters whose pH ranged from 6.1 to 8.0; within this range all the species considered seem to find favourable growing conditions.

4.2.2. The influence of water body type on the number of pleustonic species per relevé

The occurrence of the pleustonic species in different type of water body is shown in Table 12. As the table indicates, all the considered species were found only in old river beds, peat diggings and lakes. One species is missing from fish-ponds, three from rivers and drainage ditches and four from clay pits. As Table 12 shows, each of the species below was absent from one or more of the water body types: *Wolffia arrhiza*, *Lemna gibba*, *Salvinia natans*, *Riccia fluitans*, and *Ricciocarpos natans*.

Table 12. The occurrence of pleustonic species in different types of water body. (+) means that the species indicated occurred in the type of water body shown. Data originate from subset B (Fig. 1). The numbers of relevés analyzed are given in parentheses.

Water body type	<i>Lm</i>	<i>Ltr</i>	<i>Sp</i>	<i>H</i>	<i>W</i>	<i>Lg</i>	<i>Sal</i>	<i>Rfl</i>	<i>Ric</i>
old river beds (445)	+	+	+	+	+	+	+	+	+
peat diggings (463)	+	+	+	+	+	+	+	+	+
fish-ponds (161)	+	+	+	+	+		+	+	+
lakes (359)	+	+	+	+	+	+	+	+	+
rivers (25)	+	+	+	+	+	+			
drainage ditches (90)	+	+	+	+				+	+
clay pits (27)	+	+	+	+				+	

The frequency distributions of the k -species combinations with respect to the different types of water body are shown in Fig. 5. For the reasons given in section 4.1, only the subsets representing non-autonomous pleustonic assemblages will be considered in detail here and in the next sections.

As Fig. 5 shows, all the frequency distributions under study were positively skew but the proportion of relevés in the same category of k -species combinations seems to differ significantly from one water body type to another. Therefore, the null hypothesis that the proportion of relevés in a particular category is the same for all water body types was tested against the alternative hypothesis that the proportion in question differed from subset to subset. Two tests were used, the two-sided chi-square test for difference in probabilities (the $r \times c$ contingency table) and the two-sided k -sample Smirnov test. Each of the tests has drawbacks.

The chi-square test requires that the expected frequencies in each cell of a contingency table should not be too small. In the case of the categories representing 5 or more pleustonic species per relevé these requirements were not met by the data in the form in which they were originally collected (Fig. 5). These categories have therefore been combined but because of the nature of the data under study this could be done in four of the five subsets only, i.e. in peat diggings, fish-ponds, lakes and drainage ditches, so only these subsets could be used. The result of the chi-square test ($\chi^2 = 15.893$, $df = 9$, $\chi^2_{.05} = 16.92$) does not allow us to reject the null hypothesis. It may therefore be concluded that there is no difference in the proportions of relevés among the four types of water body tested.

The major drawback of the Smirnov test for several independent samples is that it may be applied only to samples of equal size, N . The subsets analyzed, i.e. old river beds, peat diggings, fish-ponds, lakes and drainage ditches were not and consisted of 154, 92, 104, 224 and 57 relevés, respectively. To overcome this difficulty, random samples of the relevés of equal size ($N = 57$) were drawn from the subsets in question (except for drainage ditches). The outcome of the Smirnov test, $T_3 = 0.175$, $T_3 (\alpha = 0.05, N = 57) = 0.229$, also does not allow us to reject the null hypothesis that there is no difference among the probability distributions compared. An ecological interpretation of the result

of both tests could be that, in the case of non-autonomous pleustonic assemblages, the frequency distribution for the occurrence of the k -species combinations is independent of the type of water body.

4.2.3. The influence of helophytic and aquatic vegetation types on the number of pleustonic species per relevé

The frequency distributions of the k -species combinations found in the subsets *Phragmition*, *Magnocaricion* and *Potamogetonion* (representative of characteristic (2), see section 4.1), are very similar to one another (Fig. 3). This suggests that the differences among them might not be statistically significant. The null hypothesis of no difference was therefore tested. Since the calculated value of the test statistic was larger than that tabled ($\chi^2 = 14.68$, $df = 6$, $\chi^2_{.05} = 12.59$) the null hypothesis was rejected in favour of the alternative that the three subsets differed significantly with respect to the characteristic tested. Since the subsets were not homogeneous the reason for this heterogeneity was of interest. Distinct discrepancies in the observed proportions of relevés, as compared with the expected ones, were found in the case of the subset of relevés representing associations of the alliance *Potamogetonion*. For this reason, this subset was excluded from the statistical analysis, and the null hypothesis of no difference tested once more. This time, the calculated value of the statistic was smaller than that tabled ($\chi^2 = 1.56$, $df = 3$, $\chi^2_{.05} = 7.82$) and the null hypothesis could not be rejected. It was thus concluded then that there was no significant difference in the number of pleustonic species per relevé observed in the subsets of relevés representing associations of the alliances *Phragmition* and *Magnocaricion*.

It can be argued, that the disagreement between the frequency distribution found in the subset *Potamogetonion* as compared with those in the subsets *Phragmition* and *Magnocaricion*, was due to the small size of the subset *Potamogetonion* ($N = 56$ relevés). This could have resulted in accidental but distinct changes in the proportions of the relevés. Since the chi-square test suggested close agreement between the proportions of relevés in the subsets *Phragmition* and *Magnocaricion*, these subsets were combined. This new subset, consisting of 528 relevés, was then compared with the subset *Potamogetonion* in relation to the number of species per relevé. The two-sample Kolmogorov-Smirnov test was used, because it is said to be usually stronger than the equivalent chi-square test (Siegel 1956; Norcliffe 1986). The result of this test ($N_1 = 56$, $N_2 = 528$, $D = 0.180$, $D_{.05} = 0.191$) did not enable us to reject the null hypothesis. Thus, it may be concluded that there is no significant difference between the frequency distributions compared. This result suggests that the number of pleustonic species per relevé does not depend on the type of vegetation considered. In the context of the considerations outlined in section 4.1 it is suggested that this interpretation may be generalized to the subsets *Nymphaeion* and *Hottonion* which were not analyzed here.

4.2.4. The influence of the two characteristics, vegetation type and water body type, on the number of pleustonic species per relevé

The frequency distributions of the k -species combinations found in the subsets *Phragmition* and *Magnocaricion* with respect to the different water body types are shown in

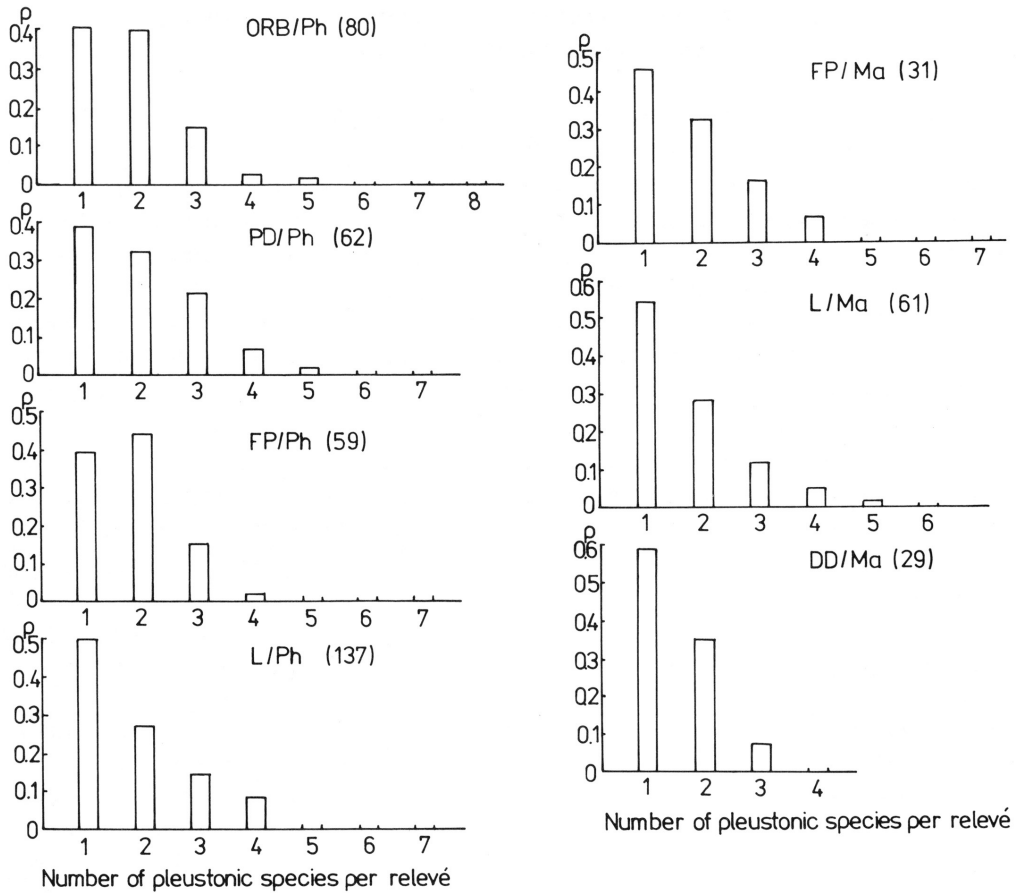

Fig. 9. Frequency distribution of k -species combinations found in the subsets of relevés representing phytocoenoses of the alliance *Phragmition (Ph)* and *Magnocaricion (Ma)*, with respect to different types of water body. The relevés analyzed originate from subset E (Fig. 1). Their numbers are given in parentheses.

Fig. 9. The null hypothesis that no significant differences existed among these distributions was tested by means of the chi-square test for k independent samples. On the basis of the result obtained ($\chi^2 = 16.71$, $df = 18$, $\chi^2_{.05} = 28.87$) the null hypothesis could not be rejected. It may be concluded that the distributions compared did not differ significantly, i.e. the proportion of relevés in a particular category was always the same irrespective of the subset considered. The ecological interpretation of this result could be that, in the case of non-autonomous pleustonic assemblages, the frequency distribution of the occurrence of k -species combinations is not determined by the combination of environmental factors here represented by combining water body type with the helophytic vegetation type.

4.3. The observed frequency distribution of pleustonic species combinations is random

4.3.1. The observed frequency distribution of k -species combinations follows a binomial distribution

The existence of the same frequency pattern for the number of pleustonic species per relevé, revealed consistently in different subsets of relevés, irrespective of the type of water body and/or helophytic vegetation, seems to suggest that the frequency of occurrence of non-autonomous pleustonic assemblages may be random, i.e. it may follow some probability distribution. Because we are dealing with binary or presence/absence data it would seem appropriate to test the null hypothesis that the number of pleustonic species per relevé had a binomial frequency distribution.

Table 13. The frequency distributions of different k -species combinations, found in the subsets of relevés representing phytocoenoses of the alliances *Phragmiton (Ph)* and *Magnocaricion (Ma)*, with respect to different water body types (WBT). The agreement between the observed and truncated binomial distributions was tested by means of the chi-square test of goodness-of-fit. (The expected distributions are not shown in this table). The term *Total* means "all water body types taken together". N = number of relevés; k = number of pleustonic species per relevé; n, p = parameters of the binomial distribution.

WBT	Syntaxon	k									N	n	p	df	χ^2
		1	2	3	4	5	6	7	8	9					
<i>ORB</i>	<i>Ph</i>	33	32	12	2	1	0	0	0	0	80	8	0.183	2	1.15 ns
<i>PD</i>	<i>Ph</i>	24	20	13	4	1	0	0	0	0	62	7	0.246	2	0.37 ns
	<i>Ma</i>	4	9	5	1	1	0	0	0	0	20	6	0.356	1	0.88 ns
<i>FP</i>	<i>Ph</i>	23	26	9	1	0	0	0	0	0	59	7	0.205	1	2.10 ns
	<i>Ma</i>	14	10	5	2	0	0	0	0	0	31	7	0.214	1	0.14 ns
<i>L</i>	<i>Ph</i>	69	37	20	11	0	0	0	0	0	137	7	0.207	2	6.88*
	<i>Ma</i>	33	17	7	3	1	0	0	0	0	61	6	0.224	2	3.48 ns
<i>DD</i>	<i>Ma</i>	17	10	2	0	0	0	0	0	0	29	4	0.260	1	0.13 ns
	<i>Ph</i>	80	78	34	7	2	0	0	0	0	201	9	0.168	2	2.34 ns
<i>Total</i>	<i>Ma</i>	68	46	19	6	2	0	0	0	0	141	9	0.154	2	0.25 ns
	<i>Ph+M</i>	148	124	53	13	4	0	0	0	0	342	9	0.162	3	0.93 ns

* $P < 0.05$

ns = not significant at $\alpha = 0.05$

The proportions of relevés falling into particular categories of the variable k , observed in the subsets *Phragmiton* and *Magnocaricion* with respect to different types of water body, are shown in Table 13. These observed frequency distributions were compared with the expected ones by means of the chi-square test of goodness-of-fit. For the reasons given in section 3.4.2, the expected distributions were treated as truncated binomial ones. The results obtained from the chi-square test are also given in Table 13. As can be seen from this table, in all cases except one the observed distributions are in close agreement with the expected (=truncated binomial) ones. The null hypothesis tested must be

rejected only in the case of the subset *Phragmition* with respect to lakes and we may suppose that this case is likely to have arisen by chance. So it may be concluded that the number of k -species combinations for the non-autonomous pleustonic assemblages under consideration may be considered random. For the reasons discussed in section 4.1, it seems very probable that this conclusion may be generalized to the subsets *Potamogetonion*, *Nymphaeion* and *Hottonion* which were not considered here.

4.3.2. The observed frequency distribution of k -species combinations and the frequency of occurrence of individual species combinations follow null model expectations

As mentioned earlier, the number of pleustonic species per relevé observed in certain subsets of relevés, may be considered binomial or random. Hence, it seems obvious that in the case of these subsets, the species composition of pleustonic assemblages is depend-

Table 14. The observed frequency distributions of the k -species combinations, revealed in the three subsets of relevés representing phytocoenoses of the alliance *Phragmition* (*Ph*) in different types of water body, contrasted with the expected ones. The expected distributions were generated by computer simulation under null model assumptions. The proportions of the species in the pool were estimated separately for each of the subsets examined. Note: the observed and expected frequencies of occurrence of the individual combinations are shown in Tables 18–20. The simulated data are presented in the form of mean values calculated for 10 replications. k = number of pleustonic species per relevé or combination; f = observed frequency distribution of k -species relevés; f^* = expected frequency distribution of k -species relevés; F = observed numbers of different k -species combinations; F^* = expected numbers of different k -species combinations; F_i = generated k -species combinations identical to the observed ones with respect to species composition; 1 = first version of the null model; 2 = second version of the null model; N = number of relevés examined; n = number of pleustonic species in the species pool.

k	f	f^*		F	F^*		F_i	
		1	2		1	2	1	2
<i>ORB/Ph</i> ($N=80, n=8$)								
1	33	18.1	34.9	4	3.8	4.0	4	4
2	32	25.3	33.1	6	6.3	6.0	6	6
3	12	24.7	10.8	5	5.9	6.2	5	5
4	2	10.4	1.2	2	4.2	1.4	1	1
5	1	1.2	0.0	1	1.7	0.0	1	0
6	0	0.3	0.0	0	1.0	0.0	1	0
<i>PD/Ph</i> ($N=62, n=7$)								
1	24	18.3	28.7	4	3.0	3.5	3	4
2	20	21.5	19.5	7	6.1	7.3	7	7
3	15	14.3	10.7	4	6.1	6.0	4	4
4	4	6.2	3.0	3	4.1	2.9	3	3
5	1	1.4	0.1	1	1.6	1.0	0	1
6	0	0.3	0.0	0	1.0	0.0	0	0
<i>FP/Ph</i> ($N=59, n=7$)								
1	23	23.9	25.1	4	2.4	3.7	3	4
2	26	22.2	26.1	7	4.6	6.5	7	7
3	9	10.8	7.8	4	4.5	4.1	3	4
4	1	1.7	0.0	1	1.8	0.0	1	0
5	0	0.3	0.0	0	1.5	0.0	0	0
6	0	0.1	0.0	0	1.0	0.0	0	0

Table 15. The observed frequency distributions of k -species combinations, revealed in the four subsets of relevés representing phytocoenoses of the alliance *Magnocaricion (Ma)* in different types of water body, contrasted with the expected ones. Note: the observed and expected frequencies of occurrence of the individual combinations are shown in Tables 21–24. The key to the symbols used is as for Table 14.

k	f	f^*		F	F^*		F_i	
		1	2		1	2	1	2
<i>PD/Ma (N=20, n=6)</i>								
1	4	7.2	6.0	2	2.3	2.0	2	2
2	9	6.9	10.0	3	3.3	2.9	3	3
3	5	4.9	3.5	1	1.9	1.0	1	1
4	1	0.9	0.4	1	1.3	1.0	1	1
5	1	0.1	0.1	1	1.0	1.0	0	1
6	0	0.0	0.0	0	0.0	0.0	0	0
<i>FP/Ma (N=31, n=7)</i>								
1	14	12.3	15.8	4	2.1	2.8	3	4
2	10	9.7	9.1	5	4.3	4.2	5	5
3	5	6.6	5.0	5	4.4	4.4	5	5
4	2	1.8	1.1	2	2.1	1.1	1	2
5	0	0.5	0.0	0	1.3	0.0	0	0
<i>L/Ma (N=61, n=6)</i>								
1	33	22.4	37.7	5	2.6	4.1	4	5
2	17	21.2	16.4	3	4.8	4.8	3	3
3	7	13.2	5.0	3	4.8	2.9	3	3
4	3	3.8	1.7	3	2.0	1.8	2	3
5	1	0.4	0.2	1	1.0	1.0	1	1
6	0	0.0	0.0	0	0.0	0.0	0	0
<i>DD/Ma (N=29, n=4)</i>								
1	17	14.3	19.1	2	2.1	2.0	2	2
2	10	9.5	8.5	4	2.8	3.6	4	4
3	2	4.4	1.4	2	2.1	1.3	2	2
4	0	0.8	0.0	0	1.0	0.0	0	0

Table 16. The observed frequency distributions of k -species combinations, revealed in the three subsets of relevés representing phytocoenoses of the alliances *Phragmition (Ph)*, *Magnocaricion (Ma)* and *Phragmition+Magnocaricion* in different types of water body, contrasted with the expected ones. Note: the observed and expected frequencies of occurrence of the individual combinations are shown in Tables 25–27. The key to the symbols used is as for Table 14.

k	f	f^*		F	F^*		F_i	
		1	2		1	2	1	2
<i>Total/Ph (N=201, n=9)</i>								
1	80	52.3	93.5	6	9.1	5.2	4	6
2	78	69.0	77.6	9	11.3	9.2	8	8
3	34	52.6	24.0	9	8.8	10.6	9	9
4	7	22.5	5.0	4	2.7	4.2	3	2
5	2	3.8	0.9	2	1.3	1.3	1	2
6	0	0.8	0.0	0	0.0	0.0	0	0

(cont.)

Table 16. Continued.

<i>k</i>	<i>f</i>	<i>f</i> *		<i>F</i>	<i>F</i> *		<i>F_i</i>	
		1	2		1	2	1	2
<i>Total/Ma (N=141, n=9)</i>								
1	68	52.2	77.7	6	3.1	5.2	4	6
2	46	48.0	43.4	7	7.1	7.9	7	7
3	19	30.0	14.6	6	7.9	6.9	6	5
4	6	9.7	4.5	5	4.9	3.6	3	5
5	2	1.1	0.8	2	1.6	1.1	1	2
6	0	0.0	0.0	0	0.0	0.0	0	0
<i>Total/Ph+Ma (N=342, n=9)</i>								
1	148	100.3	170.7	6	3.9	5.8	4	6
2	124	121.6	120.8	10	10.4	12.2	9	9
3	53	79.4	39.5	11	14.7	14.5	11	9
4	13	33.4	9.4	7	11.2	7.1	6	4
5	4	6.7	1.6	2	4.6	1.3	1	1
6	0	0.6	0.0	0	1.5	0.0	0	0

Table 17. Agreement between the observed (*f*) and expected (*f*^{*}) frequency distributions of *k*-species combinations (shown in Tables 14–16), tested by means of the chi-square test of goodness-of-fit with respect to the particular subsets of relevés examined and the two versions of null model. The more favourable outcome of the simulations carried out, expressed by the closer agreement between the distributions compared, is indicated by the calculated chi-square statistics appearing in heavy type.

Subset	Version of the null model	
	1	2
<i>ORB/Ph</i>	$\chi^2 = 27.52^{***}$ df = 3	$\chi^2 = \mathbf{0.89ns}$ df = 1
<i>PD/Ph</i>	$\chi^2 = \mathbf{2.98ns}$ df = 2	$\chi^2 = 3.68ns$ df = 2
<i>FP/Ph</i>	$\chi^2 = 1.56ns$ df = 2	$\chi^2 = \mathbf{0.80ns}$ df = 1
<i>PD/Ma</i>	$\chi^2 = \mathbf{2.27ns}$ df = 1	$\chi^2 = 3.02ns$ df = 1
<i>FP/Ma</i>	$\chi^2 = 0.67ns$ df = 2	$\chi^2 = \mathbf{0.43ns}$ df = 1
<i>L/Ma</i>	$\chi^2 = 8.77^*$ df = 2	$\chi^2 = \mathbf{3.72ns}$ df = 2
<i>DD/Ma</i>	$\chi^2 = 2.51ns$ df = 1	$\chi^2 = \mathbf{0.75ns}$ df = 1
<i>Total/Ph</i>	$\chi^2 = 34.57^{***}$ df = 3	$\chi^2 = \mathbf{7.75^*}$ df = 2
<i>Total/Ma</i>	$\chi^2 = 9.62^{**}$ df = 2	$\chi^2 = \mathbf{4.07ns}$ df = 2
<i>Total/Ph+Ma</i>	$\chi^2 = 45.46^{***}$ df = 3	$\chi^2 = \mathbf{12.70^*}$ df = 5

* $P(df=2; df=5) < 0.05$

** $P(df=2) < 0.01$

*** $P(df=3) < 0.001$

ns = not significant at $\alpha = 0.05$

Table 18. The subset *FP/Ph* (59 relevés): the frequencies of occurrence of the observed individual species combinations (*f*) and the expected ones (*f*^{*}) generated by the first (1) and second (2) versions of the null model. The expected frequencies are presented in the form of mean values calculated from the actual frequencies generated in the course of a given simulation which was replicated 10 times. Any significant surpluses and deficiencies found in the expected frequencies as compared with the observed ones are marked with an asterisk (*). These deviations were found according to the method described in a previous paper (Wolek 1988). It was found that practically the whole variability range of generated frequencies was contained within three standard deviations from the mean. Thus, the smallest and highest values generated by the 10-fold simulation can be taken as boundary or critical values. If, therefore, the observed frequency (*f*) of a particular species combination is not within this range, we may conclude that the mean expected frequency (*f*^{*}) of the species combination in question is significantly smaller (deficiency) or higher (surplus) than the observed frequency. Species: 1 = *Lm*; 2 = *Ltr*; 3 = *Sp*; 4 = *H*; 7 = *Sal*; 8 = *Ric*; 9 = *Rfl*.

Combinations	Species							<i>f</i>	<i>f</i> [*]	
	1	2	3	4	7	8	9		1	2
1-species	+							15	16.30	16.00
			+					4	7.10	4.60
				+				3	*2.00	3.50
					+			1	–	1.43
2-species	+	+						2	1.43	2.89
	+		+					17	15.90	14.20
	+			+				3	2.88	3.80
	+				+			1	1.00	1.20
	+						+	1	1.00	2.00
			+	+				1	1.00	2.00
3-species			+	+				1	2.14	1.86
	+	+	+					2	2.40	1.89
	+	+					+	1	–	1.00
	+		+	+				5	5.00	*3.00
4-species	+		+				+	1	1.00	2.25
	+	+	+	+				1	1.43	–

ent only on the frequencies of occurrence of the potentially available species in a given species pool. For each of these subsets (shown in Table 13) the proportions of the species in the pool were estimated and then used in the construction of the first version of a null model as described in section 3.4.2. Under the assumptions of the model the computer simulation was run for the individual subsets in question. As can be seen from the results obtained (Tables 14–16), the closest agreement between the observed and expected frequency distributions of the *k*-species combinations in all the characteristics considered was found in the case of the subsets *FP/Ph*, *PD/Ph*, *PD/Ma*, *FP/Ma* and *DD/Ma* whereas a rather poor one occurred for the remaining subsets. The same conclusion was arrived at by comparing the observed frequencies of occurrence of individual combinations with the expected ones (Tables 18–27).

In contrast to the results obtained earlier with respect to the null hypothesis of a binomial distribution (section 4.3.1, Table 13), the present results suggest that only in the case of the subsets of the group mentioned above can the frequency distribution of the

Table 19. The subset *ORB/Ph* (80 relevés): the observed and expected frequencies of occurrence of individual species combinations. Species: 1 = *Lm*; 2 = *Ltr*; 3 = *Sp*; 4 = *H*; 5 = *W*; 6 = *Lg*; 8 = *Ric*; 9 = *Rfl*. For detailed explanations see Table 18.

Combinations	Species								<i>f</i>	<i>f</i> *	
	1	2	3	4	5	6	8	9		1	2
1-species	+								7	4.60	5.40
		+							9	*3.70	10.20
			+						9	5.80	10.70
				+					8	5.00	8.60
2-species	+	+							2	3.11	4.10
	+		+						9	6.80	5.10
	+			+					5	3.56	7.60
		+	+		+				2	3.60	4.80
			+		+				10	*3.60	*5.10
3-species			+	+					4	5.22	6.40
	+	+	+						5	6.30	4.44
	+	+				+			1	1.33	1.17
	+		+	+					2	6.40	1.17
	+		+		+				1	1.00	1.00
4-species			+		+				3	*1.0	1.88
	+	+	+	+					1	6.80	1.00
	+		+				+	+	1	–	–
5-species	+	+	+	+	+				1	1.00	–

Table 20. The subset *PD/Ph* (62 relevés): the observed and expected frequencies of occurrence of individual species combinations. Species: 1 = *Lm*; 2 = *Ltr*; 3 = *Sp*; 4 = *H*; 5 = *W*; 8 = *Ric*; 9 = *Rfl*. For detailed explanations see Table 18.

Combinations	Species								<i>f</i>	<i>f</i> *	
	1	2	3	4	5	8	9	1		2	
1-species	+								10	7.70	10.50
		+							9	8.80	11.90
				+					4	2.00	5.50
							+		1	–	1.60
2-species	+	+							7	10.70	6.50
	+		+						3	*1.60	*1.44
	+			+					1	3.78	3.10
	+					+			1	1.00	1.33
		+	+						1	1.86	1.50
3-species			+		+				6	*2.90	4.30
			+			+			1	1.38	1.00
	+	+	+						2	3.00	1.78
	+	+		+					8	5.90	3.56
	+	+			+				1	2.00	1.38
4-species			+		+				2	*1.00	1.33
	+	+	+	+					2	2.80	1.25
	+	+			+	+			1	1.33	1.00
	+	+					+	+	1	1.00	1.00
5-species	+	+	+			+	+		1	–	1.00

Table 21. The subset *FP/Ma* (31 relevés): the observed and expected frequencies of occurrence of individual species combinations. Species: 1 = *Lm*; 2 = *Ltr*; 3 = *Sp*; 4 = *H*; 7 = *Sal*; 8 = *Ric*; 9 = *Rfl*. For detailed explanations see Table 18.

Combinations	Species							<i>f</i>	<i>f</i> *	
	1	2	3	4	7	8	9		1	2
1-species	+							11	10.6	13.00
			+					1	1.57	1.29
				+				1	1.67	1.80
							+	1	–	1.67
2-species	+		+					5	5.30	4.56
	+			+				2	1.88	2.30
	+					+		1	1.00	1.40
	+						+	1	1.33	1.25
3-species			+	+				1	1.17	1.14
	+	+		+				1	1.00	1.00
	+		+	+				1	2.44	1.38
	+		+			+		1	1.75	1.00
	+		+				+	1	1.17	1.38
4-species	+				+		+	1	1.00	1.00
	+	+	+	+				1	–	1.00
	+		+				+	1	1.00	1.00

Table 22. The subset *PD/Ma* (20 relevés): the observed and expected frequencies of occurrence of individual species combinations. Species: 1 = *Lm*; 2 = *Ltr*; 3 = *Sp*; 4 = *H*; 6 = *Lg*; 9 = *Rfl*. For detailed explanations see Table 18.

Combinations	Species						<i>f</i>	<i>f</i> *	
	1	2	3	4	6	9		1	2
1-species	+						2	3.33	3.50
			+				2	3.38	2.50
2-species	+	+					4	2.70	3.60
	+			+			4	*1.70	4.20
			+	+			1	2.20	2.44
3-species	+	+		+			5	4.00	3.50
4-species	+	+		+		+	1	1.00	1.00
5-species	+	+	+	+	+		1	–	1.00

k-species combinations be considered random (see Table 17). In the cases of the subsets *Total/Ph*, *Total/Ma* and *Total/Ph+Ma* no such conclusion can be reached.

A number of factors may have contributed to the above outcome. One of them, the most probable, is that the subsets under consideration were unrepresentative of the statis-

Table 23. The subset *L/Ma* (61 relevés): the observed and expected frequencies of occurrence of individual species combinations. Species: 1 = *Lm*; 2 = *Ltr*; 3 = *Sp*; 4 = *H*; 5 = *W*; 8 = *Ric*. For detailed explanations see Table 18.

Combinations	Species						<i>f</i>	<i>f</i> *	
	1	2	3	4	5	8		1	2
1-species	+						17	15.30	18.20
		+					1	1.33	1.60
			+				2	1.33	3.33
				+			12	6.30	14.50
2-species						+	1	–	1.71
	+	+					3	2.13	2.70
	+		+				4	4.00	3.10
3-species	+			+			10	11.60	7.70
	+	+	+				1	1.13	1.20
	+	+		+			3	4.80	1.88
4-species	+		+	+			3	5.50	2.13
	+	+	+	+			1	3.22	1.00
	+	+	+		+		1	–	1.00
	+		+	+	+		1	1.00	1.00
5-species	+	+	+	+	+		1	1.00	1.00

Table 24. The subset *DD/Ma* (43 relevés): the observed and expected frequencies of occurrence of individual species combinations. Species: 1 = *Lm*; 2 = *Ltr*; 3 = *Sp*; 4 = *H*. For detailed explanations see Table 18.

Combinations	Species				<i>f</i>	<i>f</i> *	
	1	2	3	4		1	2
1-species	+				14	12.40	15.10
				+	3	2.00	4.00
2-species	+	+			1	1.75	1.70
	+		+		1	1.50	1.25
	+			+	6	6.80	4.20
		+		+	2	*1.00	2.13
3-species	+	+	+		1	1.00	1.20
	+		+	+	1	1.67	1.20

tical population of the frequencies of occurrence of pleustonic species (see Appendix H). To remove this potential source of error, a correction for non-representativeness was incorporated and formed the basis for a second version of the null model. This correction consisted of additional information concerning the probability of the occurrence of each species in every category of the *k*-species combinations. The correction was an attempt to

Table 25. The subset *Total/Ph* (201 relevés): the observed and expected frequencies of occurrence of individual species combinations. Species: 1 = *Lm*; 2 = *Ltr*; 3 = *Sp*; 4 = *H*; 5 = *W*; 6 = *Lg*; 7 = *Sal*; 8 = *Ric*; 9 = *Rfl*. For detailed explanations see Table 18.

Combinations	Species									<i>f</i>	<i>f</i> *		
	1	2	3	4	5	6	7	8	9		1	2	
1-species	+										32	30.60	34.70
		+									18	*8.40	19.80
			+								13	7.80	*18.10
				+							15	*5.50	19.20
								+			1	–	1.33
								+		1	–	1.50	
2-species	+	+									11	*17.30	12.20
	+		+								29	*18.60	*18.70
	+			+							9	13.50	13.80
	+						+				1	1.00	1.00
	+							+			2	1.20	*1.00
		+	+								4	6.00	8.60
			+		+						16	*5.10	*8.70
		+			+					1	–	–	
			+	+						5	5.10	*12.00	
3-species	+	+	+								9	14.90	*5.40
	+	+		+							8	*13.00	5.89
	+	+			+						1	1.00	1.80
	+	+					+				1	1.33	1.57
	+	+							+		1	1.20	1.00
	+		+	+							7	*10.90	3.25
	+		+		+						3	*1.20	*1.14
	+		+			+					3	*1.20	*1.00
		+							+	1	1.00	1.00	
4-species	+	+	+	+							4	*13.20	*1.00
	+	+			+				+		1	–	1.00
	+	+						+	+		1	1.00	–
	+		+					+	+		1	1.00	–
5-species	+	+	+	+	+				+	+	1	1.86	1.00
	+	+	+								1	–	–

reduce the difference between the observed and expected frequencies resulting from non-random causes.

With the correction taken into account, null pleustonic assemblages were again generated by computer simulation with respect to the same relevé subsets as before. The results obtained, shown in Tables 14–17, suggest that, with the exception of the subsets *Total/Ph* and *Total/Ph+Ma*, the degree of agreement between the observed (*f*) and expected (*f*^{*}) frequency distributions of the *k*-species combinations, in all characteristics

Table 26. The subset *Total/Ma* (141 relevés): the observed and expected frequencies of occurrence of individual species combinations. Species: 1 = *Lm*; 2 = *Ltr*; 3 = *Sp*; 4 = *H*; 5 = *W*; 6 = *Lg*; 7 = *Sal*; 8 = *Ric*; 9 = *Rfl*. For detailed explanations see Table 18.

Combinations	Species									<i>f</i>	<i>f</i> *		
	1	2	3	4	5	6	7	8	9		1	2	
1-species	+										44	41.70	*49.50
		+									3	2.00	3.38
			+								3	2.00	3.38
				+							16	*8.30	19.70
								+			1	–	1.14
2-species									+		1	–	1.71
	+	+									8	6.90	5.70
	+		+								10	8.00	6.80
	+			+							22	26.20	18.90
	+						+				1	1.25	1.00
3-species										+	1	1.50	1.00
		+		+							3	2.86	3.70
			+	+							1	2.75	*5.00
	+	+	+								2	3.40	2.40
	+	+		+							9	12.40	*4.20
4-species	+		+	+							5	8.40	2.80
	+		+					+			1	1.00	1.00
	+		+						+		1	1.00	1.33
	+						+		+		1	1.00	–
	+	+	+	+							2	5.40	2.17
5-species	+	+	+		+						1	–	1.20
	+	+		+						+	1	1.17	1.00
	+		+	+	+						1	1.00	1.50
	+		+					+	+		1	–	1.00
	+	+	+	+	+						1	1.00	1.33
	+	+	+	+		+				1	–	1.00	

considered, was closer than that previously found; in eight out of the ten cases examined the differences between these distributions were not statistically significant (Table 17). In most cases, also, a better fit occurred between the observed and expected frequencies of occurrence of the individual species combinations (Tables 18–27).

In the cases of the subsets *Total/Ph* and *Total/Ph+Ma* the results obtained using the second version of the null model were not so clear. On the one hand, closer agreement had been obtained between the observed (*f*) and expected (*f**) frequency distributions of the *k*-species combinations, although the differences between these distributions were still significant (Table 17). By contrast, however, the results obtained using this version of the model showed that the agreement between the observed and the expected frequencies of occurrence of individual combinations was not closer (Tables 18–27) as might

Table 27. The subset *Total/Ph+Ma* (342 relevés): the observed and expected frequencies of occurrence of individual species combinations. Species: 1 = *Lm*; 2 = *Ltr*; 3 = *Sp*; 4 = *H*; 5 = *W*; 6 = *Lg*; 7 = *Sal*; 8 = *Ric*; 9 = *Rfl*. For detailed explanations see Table 18.

Combinations	Species									<i>f</i>	<i>f</i> *		
	1	2	3	4	5	6	7	8	9		1	2	
1-species	+										76	75.90	85.30
		+									21	*6.70	25.00
			+								16	*7.11	18.00
				+							31	*11.30	*38.90
							+				2	-	2.00
								+		2	-	1.89	
2-species	+	+									19	28.70	20.40
	+		+								39	30.30	*24.80
	+			+							31	37.40	31.60
	+						+				2	1.00	1.33
	+							+			2	2.14	*1.00
	+								+		1	2.43	1.00
		+	+								4	4.70	7.40
			+		+						19	*7.40	12.50
			+	+						1	-	-	
					+					6	6.40	*16.50	
3-species	+	+	+								11	14.90	9.20
	+	+		+							17	24.10	*7.80
	+	+			+						1	1.14	1.33
	+	+				+					1	1.33	1.17
	+	+							+		1	1.17	1.67
	+		+	+							12	*19.70	*6.00
	+		+		+						3	1.71	1.00
	+		+			+					3	*1.33	1.17
	+		+					+			1	1.43	-
	+		+						+	+	2	2.40	1.14
						+			+	1	1.00	-	
4-species	+	+	+	+							6	*20.10	*1.50
	+	+	+		+						1	1.83	1.50
	+	+			+			+			1	-	-
	+	+						+	+		1	1.00	-
	+	+		+					+		1	1.86	1.17
	+		+	+	+						1	1.56	1.20
5-species	+		+								2	*1.00	-
	+	+	+	+	+						3	1.75	*1.60
	+	+	+					+	+		1	-	-

have been anticipated from the results discussed above. This phenomenon even occurred in the subset *Total/Ma* where the difference between the observed and expected number of species per relevé ceased to be significant after incorporating the correction for non-representativeness into the null model (Tables 17 & 26).

In the cases of the subsets *Total/Ph*, *Total/Ph+Ma*, and to some degree in *Total/Ma*, simulation with the help of the first and second versions of the null model produced worse results than those given by their component subsets (i.e. *ORB/Ph*, *PD/Ph*, *FP/Ph*, *FP/Ma*, *PD/Ma*, *L/Ma* and *DD/Ma*). This outcome suggests that in nature there may be different pools of pleustonic species, each specific to a different combination of environmental factors, here represented by the particular combination of helophytic vegetation type with water body type.

5. DISCUSSION

5.1. Data collection

Sampling method

Following the Zürich-Montpellier School, a phytosociologist delimits plant associations with the help of the Braun-Blanquet method and next he tries to correlate a given characteristic species combination with a specific combination of ecological factors. With the subjective procedure of making relevés it is easy to obtain distinctive associations and to find convincing sets of underlying ecological factors. As is evident from the paper by Dzwonko and Grodzińska (1979), the use of a multivariate method to distinguish plant associations can eliminate, at this stage of the phytosociological analysis, any element of subjectivity which exists, but it cannot yield reliable information on the relationships between the associations distinguished and their environment; only analysis of objective data samples can achieve that.

With the Braun-Blanquet method, relevés of intermediate stands are often omitted when a vegetation table is made. In this way the ecological scale of character-species found in a collection of relevés is truncated on both sides; only the middle part of the scale is recorded. Sometimes even these relevés are not made or selection in the field is biased in favour of suspected character-species (see also Barkman 1990). Stand selection is based on the assumption that vegetation structure is discontinuous – without this assumption selection of stands would not be feasible. So, when employing this method, a phytosociologist makes some tacit assumptions about the vegetation structure under examination before the study itself begins. The discontinuity imposed by the method used is built automatically into the data sampled and in this way inevitably determines what plant associations will be revealed. Therefore, it is of the greatest importance how a data sample is collected, randomly or not, because at this stage the result of the later data analysis is decided.

In order to eliminate such a factitious structure from the data set, the statistical analysis presented in this paper is based on the set of all those relevés in which at least one of the pleustonic species considered was present. The advantages of this sampling method are that (1) it pays special attention to registering the whole ecological amplitude of the species considered and (2) it ensures that the data analysis only reveals a phytoso-

biological pattern if it actually exists in the vegetation considered. These differences between the Braun-Blanquet approach and the one presented in this paper are crucial to the result of the statistical analysis.

Statistical inference

As is widely known, to arrive at a reliable conclusion about a statistical population a random or representative sample should be drawn from that population. In the present paper a relatively weak form of this principle has been applied. It states that a sample should at least be representative with respect to the characteristic (or characteristics) considered and it will be called the *minimum requirement rule*.

The minimum requirement rule applied in the present study has been imposed by the nature of the data at our disposal. It is clear, however, that inferences will be reliable only if the sample used is genuinely random. If this cannot be guaranteed we can merely draw conclusions about the sample examined and generalize them as applying to the whole population in the form of some scientific hypotheses which should then be tested by means of a proper random sample. The results of analyses presented in this paper have been obtained in precisely this way.

It must be emphasized here that strange opinions are sometimes expressed by ecologists on this matter. On the one hand it is asserted (e.g. Kershaw & Looney 1985) that the use of statistical tests demands that the original sample should be taken at random because in the case of non-random sampling statistical analysis is not valid (p. 26). By contrast, on p. 17 and 33, the authors claim that all approaches to the sampling problem are based on common sense rather than on a reliance on complex statistical theory. I simply cannot follow this logic; as certain conditions must be met if a given statistical test is to be used, the sampling method cannot therefore be the matter of personal choice. The restrictions may sometimes be relaxed but the consequences of this action should always be taken into account.

Relevés as a source of information

Relevés are said to be full of valuable phytosociological, biogeographical and ecological information. My own experience does not support this view. Not all the relevés potentially available were found to be suitable for the purposes of this study. Some of them had not been assigned to a definite association by original authors and in many cases environmental factors had been recorded imprecisely. For example, the value of the water pH in a given relevé was inaccurately recorded (e.g. it was given as "pH ca. 7") or the pH was not measured in a particular stand at all. Instead a few measurements were taken at various points of a given water body only. Data of this sort are useless because they cannot be employed in detailed statistical analysis. Relevés with inadequacies of these kinds have been found before (Wołek 1974a; Wołek & Pancer-Kotejowa 1988). For these reasons, relevés are here considered to be of little importance from the point of view of statistical analysis.

It seems that non-autonomous pleustonic assemblages constitute excellent material for investigations on combinations of pleustonic species because their habitats, repre-

sented by definite aquatic and helophytic phytocoenoses, may be easily characterized with the help of dominant, aquatic or helophytic, species. In this way samples will not only be representative but also comparable with other samples drawn by the same method. Samples originating from different sites but from patches dominated by the same aquatic or helophytic plant species may be treated as replications of the same experiment. By contrast, with autonomous pleustonic assemblages, it is very difficult to define their habitats because there are no distinct and reliable characteristics in relation to which the results obtained can be interpreted. Autonomous assemblages are, therefore, considered to be of little importance as a basis for investigations on the effect of habitat factors on the species composition of pleustonic assemblages.

Presence/absence data

In the present study, community analysis was in principle based on presence/absence data because by means of these data it is easy to test the hypothesis that exclusion of some species or species combinations really does exist in the field.

By examining quantitative data we can reveal variations in the abundance of the species present. These fluctuations may be caused by year to year variations in the climatic circumstances, the physico-chemical properties of the water and/or biotic relationships among plant and animal organisms. Although tests based on abundance data may, for example, detect interspecific relationships that remain unnoticed in an analysis of presence/absence data, it is difficult (if not impossible) to predict the ultimate effect of the above-mentioned ecological factors on the species composition of the vegetation examined. Ecological mechanisms, such as interspecific interactions, for example, do not lead inevitably to extinction; they are more likely to reduce population numbers (Haila 1983; Moulton & Pimm 1986). On the other hand, the differences observed in the abundances may have arisen as a consequence of fluctuations occurring either in the ecological factors and/or in the ecological system itself (deterministic chaos). Such quantitative fluctuations in pleustonic assemblages were registered by Landolt (1986, see also references cited therein). He also observed qualitative changes in species composition from year to year. Observations of this kind do not, however, change the facts that (1) it is difficult to predict the ultimate outcome of the variations in relative abundance of species occurring in combination and (2) usually no qualitative differences occur as a result of quantitative changes in abundance, unless some extreme conditions begin to prevail in a given ecological situation, e.g. extreme climatic conditions (see den Hartog & van der Velde 1988). Because the main aim of this study was to detect non-random patterns in the species composition of pleustonic assemblages, qualitative data were preferred to quantitative.

Scale of observation

Pattern is scale dependent. The scale of an investigation largely governs questions involving procedures, observations, results and conclusions. Hence it may have a profound effect on any patterns that are detected. Because different patterns emerge from different scales of investigation it is obvious that there is no single correct scale at which

ecological phenomena should be studied. The choice of an appropriate scale for community analysis is therefore the most important decision in any research programme. Many publications reiterate the critical importance of scale of observation for ecological studies (e.g. Dayton & Tegner 1984; Wiens 1986, 1989; Wiens *et al.* 1986; Giller & Gee 1987; Angelstam 1992; Levin 1992; Allen *et al.* 1993; Horne & Schneider 1994).

In the present study the scale of observation has not been considered in detail because it was unequivocally determined by the size of the relevés analyzed. In the case of the phytocoenoses of pleustonic, aquatic and helophytic plants, the relevé size ranged from (2–)10 to 100(–250) m². According to the scheme described by Giller and Gee (1987) and Grubb (1987) such a range is considered microscale.

5.2. Relationships between pleustonic species assemblages and ecological factors

Water pH

Field observations compiled by Landolt (1986) showed that the pH of water bodies inhabited by Lemnaceae species ranged from 3.5 to 10.4, but these species were rarely found in waters with pH values at the extremes of this range. Investigations carried out by Landolt and Zarzycki (1994) in Argentina revealed that, in the field, the pH of water bodies containing pleustonic plants ranged from 5.5 to 9.5. Their result is in close agreement with the pH range 5.5–9.0 found by the present author in Poland. Comparison of the frequency distributions of pH values from Argentina and Poland reveals further striking similarities (Fig. 10). To make both distributions comparable, the pH values from Poland were grouped into the same classes as those chosen by Landolt and Zarzycki (1994). Ignoring for a moment some differences in the frequencies observed, let us focus on the shapes of the diagrams representing the two distributions. We can see that (1) they are approximately symmetrical, (2) the majority of observations falls between the pH values 6 and 8, and (3) the right-hand distribution tail is in both cases larger than the left-hand one. It seems that, in nature, pleustonic species do not tolerate a pH value lower than 6. On the other hand, although the frequency of waters inhabited by pleustonic species at pH > 8 clearly decreases, it seems that there is no boundary pH value which drastically limits the occurrence of pleustonic species in the field. The findings presented above suggest also that a characteristic pattern of frequency of occurrence exhibited by pleustonic species (not only Lemnaceae species!) exists and that this pattern seems to be universal. It would be interesting to test this hypothesis.

The differences in frequency which occur in the same categories of the two distributions may result from different proportions of the water body types present in the data sets compared. This hypothesis cannot, however, be examined here because of lack of appropriate information concerning the water body types which did occur, and in what proportions, in the data set from Argentina.

It is difficult to say whether, in Poland, water pH values lower than 6 or higher than 8 (or 9) really do inhibit the growth of Lemnaceae species. On the one hand, such a supposition seems to be supported by the fact that *Lemna minor*, *L. trisulca* and *Spirodela*

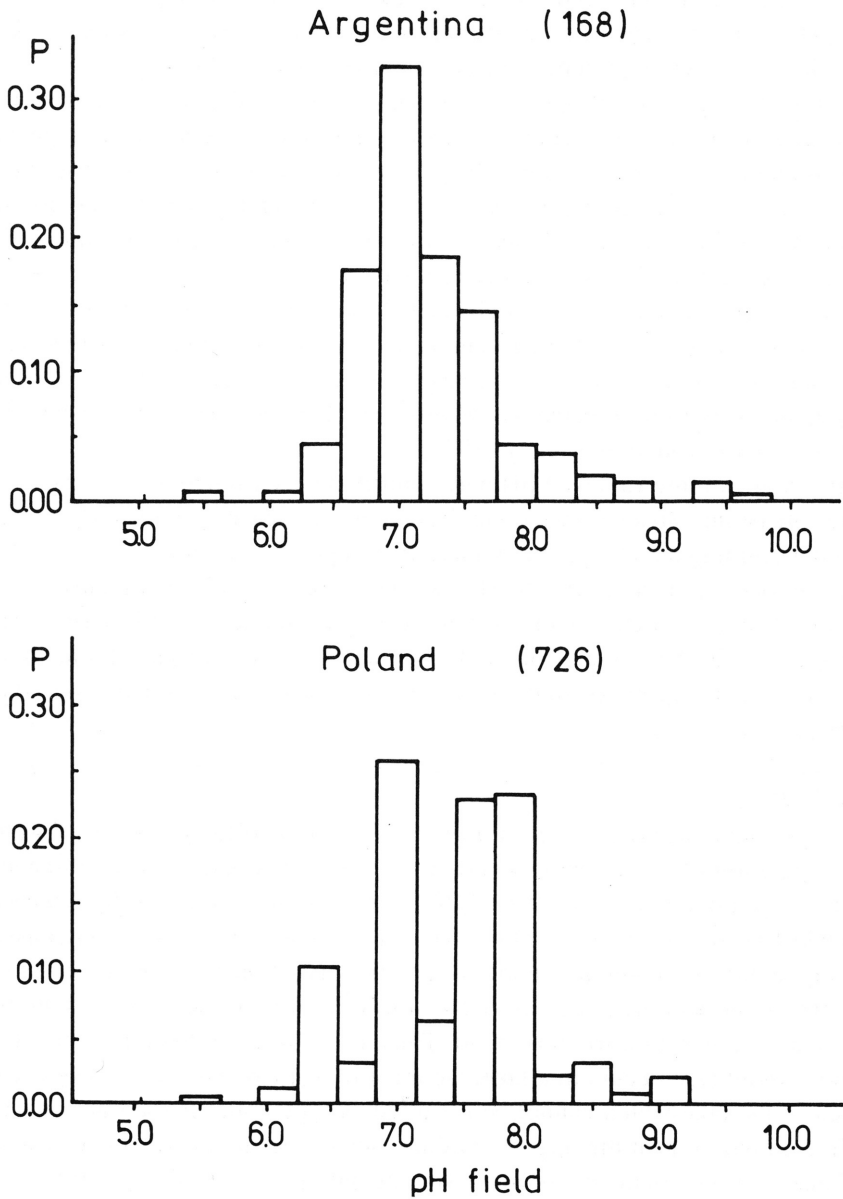

Fig. 10. Frequency distribution of water pH values from Argentina (acc. to Landolt & Zarzycki 1994) contrasted with those from Poland (present study). The numbers of relevés analyzed are given in parentheses. p = proportion of relevés expressed as a decimal.

polyrhiza are rarely found in waters with extreme pH values (Tables 3 & 4). However, this correlation may be more apparent than real. Field observations made by Landolt and Wildi (1977) and Zimmermann (1981) suggest that some pleustonic species tolerate a wider range of pH values than would follow from Table 11; of the species considered in

the present paper, *L. minor* occurs in the field at pH 5 or lower and *S. polyrhiza* and *L. gibba* at pH 9 or above. The rare occurrence of Lemnaceae species in waters of low pH is probably due to nutrient deficiency in such waters (Landolt 1986).

According to experimental observations, most Lemnaceae plants will grow in adequate media at a pH lower than 4 and some species are able to grow even at a pH near 3. It was also found that the lower growth limit of pH is species and clone specific; among others most clones of *Spirodela polyrhiza*, *Lemna gibba* and *L. trisulca* did not tolerate a pH lower than 4, but clones of *L. minor* would grow in a suitable medium with a pH ranging between 3.2 and 3.5 (Landolt & Kandeler 1987).

Experimental investigations by Hicks (1932) showed that the growth of Lemnaceae species was very poor at a pH higher than 8 and *Lemna minor* and *L. trisulca* were prone to die under such conditions. His findings have been confirmed by field observations made by Keddy (1976). A negative correlation between the growth of *L. perpusilla* Torr. and a pH 8 was also found by McLay (1974).

It seems that extreme values of pH may control the occurrence of Lemnaceae or, more generally, pleustonic species in the field and, in this sense, pH may be an important factor in determining aquatic plant community composition in general (a view long held by some authors, e.g. Pearsall 1920, Moyle 1945, Spence 1967) and pleustonic assemblage composition in particular (see section 3.4.1 and references cited therein). However, it seems that within the range of pH 6–8(–9?) the occurrence of pleustonic species, and therefore the species composition of pleustonic assemblages, are not determined by water pH as such.

Water body type

There are some papers dealing with the vegetation of different types of water body, e.g. the vegetation of old river beds, lakes, peat diggings, fish-ponds, drainage ditches and so on (e.g. Podbielkowski 1960, 1967, 1969; Tomaszewicz 1969; Krzywańska & Krzywański 1972). Investigations of this kind are probably based on the tacit assumption that each type of water body determines a specific type of plant assemblage. As is widely known, pleustonic assemblages develop in localities where there are no strong movements of water caused by current or wind. Thus, if we observe that a certain autonomous pleustonic assemblage occurs in a lake, we must recognize that it is always encountered in an area of the lake which cannot be regarded as typical but from a part more closely resembling a pond or peat digging. A similar situation occurs in rivers. Individual pleustonic plants may be found in its main stream but typical, well developed pleustonic assemblages occur only in places with stagnant or slow flowing water. In the light of the above, it seems clear that a given water body should be considered from two different points of view, firstly as providing a set of suitable, potentially available sites which can be inhabited by pleustonic species and secondly as a complete entity, irrespective of the number of potentially available sites it contains. The term *suitable sites* is interpreted here as “sites favourable for the growth of pleustonic species”.

In the first case, only those environmental factors should be taken into account which are operating at the given suitable site. The factors are independent of the type of water

body. Because the effect on the occurrence of pleustonic species of the combination of factors characteristic of the given type of water body is not taken into account, no information is yielded concerning the probability of occurrence of the species in different types of water body. Consequently, if similar combinations of ecological factors occur at all suitable, potentially available sites, then, independently of water body type, these sites should be (statistically!) similar with respect to the floristic composition of the pleustonic assemblages inhabiting them.

In the second case we have to deal with the combination of factors which determine the type of water body. These factors also determine the number of suitable sites and hence the probability of the occurrence of a species in a particular type of water body, i.e. they determine the proportions of the species in a species pool. Because different types of water body contain different numbers of suitable sites, different species pools will have been created in them. Consequently, different species combinations will have been formed in different water body types.

The factors which determine the type of water body should not be mistaken for the local combination of ecological factors which control the growth of the species which occur at a given site. The type of water body can be compared to a geographical region. In each case the probability of occurrence of the species considered (i.e. their proportions in the species pool) may be estimated, but the determinants of the geographical region (as well as the type of water body) cannot be used to explain the growth and dynamics of species populations at any particular site. Only by considering local environmental factors can we do that. These two different methodological approaches should not therefore be confused and they are carefully separated in further discussion of the results of this study.

If only presence/absence data are under consideration, the results presented in this paper seem to suggest that the occurrence of pleustonic species is independent of water body type. The lack of *Wolffia arrhiza*, *Lemna gibba*, *Salvinia natans*, *Riccia fluitans* or *Ricciocarpos natans* from certain types of water body does not contradict this inference because their absence does not seem to be caused by water body type. In general they are found in the field less often than *L. minor*, *L. trisulca*, *Spirodela polyrrhiza* or *Hydrocharis morsus-ranae* (Wolek 1983), so the absence of one or more of these species in a given water body may simply mean that no propagules of the species have ever reached it.

The overlooking of these species may also explain their apparent absence from some relevés. Certain plants are small in size (*Wolffia arrhiza* and *Riccia fluitans*, for example) and they are likely to be hidden from view among other pleustonic species, especially if they are not abundant in the given water body. As to *Lemna gibba*, it may form flat fronds that can be mistaken for those of *L. minor* (de Lange & Pieterse 1973; Wolek 1974a; de Lange 1975; Kandeler 1975; Landolt 1975; Pieterse 1975; de Lange & Westinga 1979; Pechenyuk 1984). On the other hand, however, many investigators are especially interested in these species because of their rarity in nature and/or their interesting biology, ecology etc. (Kordakow 1970; Olaczek & Krzywański 1970; Kępczyński & Fabiszak 1972; Ochyra & Tomaszewicz 1979). For this reason, therefore, it seems unlikely that their presence could be overlooked. Because of the lack of detailed, quantitative and qualitative data a final answer to this question cannot be provided now. For the

present it must be assumed that the lack of some species in certain water body types results from the sampling procedure, rather than from differences in the ecological requirements of the species under consideration. Because pleustonic species do occur at suitable sites in a particular water body it seems reasonable to suppose (in the context of the above considerations relating to the concept of water body type) that it is not the chemical composition of the water that confines pleustonic species to some water body types only. The constraints may be of a physical nature as is shown below.

Although the occurrence of a species does seem to be independent of the water body type, we cannot exclude the possibility that habitat conditions, specific to a particular type of water body, may be responsible for the selection of certain genotypes of pleustonic species. In small bodies of stagnant water (e.g. ponds, peat diggings, old river beds) *Lemna trisulca* is often a component of pleustonic assemblages and is usually found floating just below the surface of the water. In lakes, on the other hand, I have observed a genotype (?) of *L. trisulca* which grows on the lake bed in the shallows of the littoral zone, probably due to the wave motion of water. A similar observation was made by Rejewski (1981).

The data collected in the different types of water body are, probably, to some degree at least, reliable as far as the influence of the particular type of water body on the development of pleustonic assemblages is concerned. Since, generally, it was the best developed autonomous pleustonic assemblages which were mainly recorded, it can be assumed that these would not have been omitted had they been found in the course of phytosociological investigations. So these data should furnish reliable information as to the presence of species rich pleustonic assemblages in different types of water body. They suggest (Fig. 5) that the assemblages occurring in old river beds and peat diggings contain a greater number of pleustonic species than those growing in other types of water body. This is probably due to the higher ecological stability of old river beds and peat diggings. Conditions in the remaining water body types are ecologically more unstable. Pleustonic assemblages occurring in them are exposed to wave motions or currents (lakes, rivers, drainage ditches), water treatment (fish-ponds) and mechanical excavation used to maintain the efficiency of drainage ditches. Under such conditions pleustonic assemblages are often destroyed. It seems, therefore, despite what has been said earlier, (see section 4.2.2) that the number of species in a particular pleustonic assemblage and its species composition can be determined by the nature of the water body, in the sense that specific combinations of environmental factors, especially physical ones, characteristic of that water body type, may control the probability of the occurrence of pleustonic species and their assemblages. This provides a second approach to the concept of water body type. The frequency distributions for the occurrence of k -species pleustonic assemblages are positively skew for sure, and similar in shape to those considered earlier, but it is doubtful whether, in this case, we can trust the results of the statistical tests presented in section 4.2.2.

Vegetation type

The above remark also applies if we consider the relationships between pleustonic species and aquatic and helophytic plants. It was found that the frequency distribution for the occurrence of k -species pleustonic assemblages was also positively skew and showed little variation in shape for the different aquatic and helophytic vegetation, as well as for the different combinations of vegetation type with water body type. It seems, however, very unlikely that the frequency of occurrence of different k -species pleustonic assemblages will always be the same for various combinations of ecological factors, although such a conclusion is suggested by the statistical tests used earlier (see sections 4.2.3 and 4.2.4). The two examples presented below show that rooted plants may influence the growth of pleustonic species.

McLay (1974) found that the growth of *Lemna perpusilla* Torr. was diversified in accordance with the lake zone occupied by it. The growth of *L. perpusilla* was most vigorous in the *Scirpus californicus* (C. A. Mey) Steud. zone, good in a zone close to the shore and poor in the *Potamogeton pectinatus* L. zone. Under laboratory conditions, *L. perpusilla* was cultivated in water from the different zones of the lake under study. The results obtained fully confirmed the field observations.

Van der Valk and Davis (1978) investigated the role of seed banks in vegetation dynamics. They found 4213 turions of *Spirodela polyrhiza* per 1 m² in an area dominated by *Scirpus fluviatilis*, less than 100 turions per 1 m² in a stand composed mainly of *S. validus* and *Carex* spp. and no turions at all per 1 m² in an area free from emerged plants.

As a result of the discussion presented up to now it may be concluded that the types of water body and aquatic and helophytic vegetation play some role in structuring pleustonic assemblages.

Some authors (e.g. Mueller-Dombois & Ellenberg 1974; Fitter 1987; Tilman 1989; Barkman 1990) claim that if we consider the relationships between dominant and dependent plant species, we have not to do with direct interactions between the species because dependent species are not dependent on a particular dominant species (the only kinds of direct interaction are parasitism, predatoriness and mutualism). We should concentrate exclusively on indirect relations which are realized via the environment; a dominant plant influences environmental factors and consequently subdominant plants. It seems that any interactions which occur between pleustonic and rooted species are of a similar nature. Phytocoenoses of rooted plants (i.e. dominant plants in this situation) influence such abiotic factors as light conditions, motion, temperature and chemical composition of the water and in this way may influence pleustonic assemblages.

Abiotic factors, symbolized here by water pH, water body type and aquatic and helophytic vegetation type, act on a local scale. Other abiotic factors, such as climatic ones, exert influence on both a global and regional scale.

The relationship between the occurrence of Lemnaceae species and climatic factors was described by Landolt (1981, 1982, 1984 and summary in a paper of 1986). As his results show, Lemnaceae species differ in their climatic requirements and tolerance. There is, therefore, no doubt that climatic differences in the world determine the geographic pattern of these species and result in different compositions of pleustonic as-

semblages (Landolt 1986; Landolt & Zarzycki 1994). To be precise, climatic factors influence the composition of a species pool in a particular region and hence, indirectly, the species composition of pleustonic assemblages. Climatic factors may also act on a local or even on a microscale.

Changes in the abundance of the component species of a particular pleustonic assemblage, due to abiotic factors taking place from year to year and from season to season in a single year, lead to changes in the dominance hierarchy and, sometimes, can even give rise to changes in the species composition of the pleustonic assemblage itself (see e.g. data presented by Tüxen 1974 and Landolt 1986).

The potential importance of biotic interactions in structuring pleustonic assemblages is discussed below.

Competition and allelopathy

Laboratory experiments have shown competitive and/or allelopathic interactions to exist between some pleustonic species studied in two-species cultures (e.g. Clatworthy & Harper 1962; Bornkamm 1963; Rejmánková 1974; Wolek 1974b, 1979, 1984). Competition is considered to be a very important factor determining the distribution of pleustonic species and hence their co-occurrence patterns in the field (Landolt 1986; Landolt & Zarzycki 1994). Because these authors did not support their opinion by citing any detailed field investigations examining the role of interspecific competition in organizing pleustonic communities, it is supposed here that their view must have been intuitive, derived from the conviction, popular among ecologists, by which “there is no question that competition occurs” (see Peters 1991).

For a long time ecologists have regarded interspecific competition as a convenient explanation of differences between the physiological and ecological responses of plants to an environmental factor. They have also accepted the occurrence of competitive exclusion as an explanation for the existence of communities in which certain combinations of ecologically similar species appear to be rare or absent. Interpretations of this sort are basically wrong for the following reasons.

Firstly, there is difficulty in demonstrating the effects of competition in nature. Tests for competition are inadequate and unequivocal interpretation of the results is impossible (Connell 1990). Pianka (1981) and Barkman (1990) claim that the evidence at our disposal in support of the existence of competition in the field is solely the set of our interpretations, not of empirical facts. This is why inferring the existence of competition from ecological (=observational) data must be done very carefully.

Secondly, competition does not occur in all ecological situations. Competition has been shown to occur among individuals and species in the majority, but not all, of the instances where it was sought (Connell 1983; Schoener 1983). According to Pickett (1980), in conditions of non-equilibrium, interspecific competition is unlikely to be influential. It was also found that use of the same resources need not imply competition for them (Price 1984; Wolek 1984; Simberloff & Dayan 1991).

Thirdly, competition, if it exists, is not always a major force organizing animal and plant communities. The role of competition in determining community patterns has long

been a matter of debate. Different opinions exist in this respect. On the one hand, some authors regard interspecific competition as a potent organizing force in communities, but this view is questioned by others on various grounds (e.g. Strong *et al.* 1984; Price *et al.* 1984; Grace & Tilman 1990, and references cited therein).

Fourthly, the consequences of competition are not well-defined. It is known that each piece of evidence claimed as demonstrating a manifestation of competition may also be interpreted as the result of the effects of other ecological factors, mechanisms or processes. Therefore the first task in any community analysis must be to demonstrate unequivocally the occurrence of competition (Ernst 1978; Silvertown 1983; Wolek 1983, 1988; Connell 1990, and others). The above methodology must be strictly adhered to, otherwise competition may provide the theory that can explain everything. Then, all possibility of disproving that theory will have been eliminated (Rathcke 1984).

Fifthly, and most importantly, there is no precise definition of the term *competition*. This fact has important implications for methodological questions and for the demonstration of competition in the field.

The need for precise definitions of ecological terms (e.g. Peters 1991) is not a purely semantic one as is claimed by some. In the absence of a clear, operational definition of a particular term, different users develop their own independent definitions which are often inconsistent or even contradictory. Consequently when studying apparently similar ecological problems they base their studies on different assumptions, obtain incomparable results and in addition they cannot understand one another.

As for the definition of competition, there is no uniformity of view in this respect among ecologists (e.g. Keddy 1989; Law & Watkinson 1989; Peters 1991). Many formal, informal or tacit definitions of the term exist in the ecological literature. For example, Milne (1961) was able to find 12 definitions. According to him, competition remains an omnibus term. In addition competition is an author-specific term. Although these definitions differ in detail, their common and permanent element is an **assumption** that competition takes place when two or more species vie for a resource whose supply is insufficient for all of them. **Consequently**, species in competition negatively affect the growth of one another. In some ecological situations a weaker competitor may be excluded from a community by a stronger one (competitive exclusion principle). Thus, this consequence might seem to be a good criterion for demonstrating of competition but, alas, this interaction does not produce competition-specific patterns, as has been mentioned above. Because inhibition of population growth in a community may arise for reasons other than competition for common resources, arguments from observational data that this interaction has occurred may be unsound.

The above shows why we must have numerous reservations about such an intuitive conclusion as that reached by Landolt (1986) and Landolt and Zarzycki (1994) quoted hitherto.

Results obtained in laboratory short-term experiments provide a valuable insight into some ecological mechanisms and processes, but they cannot be directly generalized to field conditions because the effects of such biotic factors as competition and allelopathy depend to a great degree on the particular ecological context (Wolek 1979).

Results obtained by stochastic simulations suggest that the floristic composition of pleustonic assemblages is determined by random processes which govern the community assembly. It may be concluded then, that such biotic interactions as allelopathy and interspecific competition, occurring among pleustonic species on the one hand and between these species and aquatic and helophytic species on the other, even if they exist in the field, control the abundance of the component pleustonic species populations rather than the numbers of species in the pleustonic assemblages.

According to some authors, aquatic plants like *Nymphaea*, *Nuphar* or *Myriophyllum* exhibit allelopathy, producing certain inhibitive substances keeping waters in which they grow free from Lemnaceae (cited following Landolt & Zarzycki 1994). Observations made by the present author are inconsistent with these results; it was found that pleustonic assemblages containing the greatest numbers of pleustonic species occurred in phytocoenoses belonging to the alliance *Nymphaeion* (Wolek 1991). This could be an example illustrating how this interaction might depend on the ecological context.

In practice, it may be very difficult to distinguish in the field between the effects of allelopathy and competition on the one hand and between biotic and abiotic factors on the other (Wolek 1984).

Herbivory

Herbivory may significantly alter the composition of communities in all ecosystems (Huntley 1991 and references cited therein; see also Harper 1977; Crawley 1983; Allan 1995) although, according to Sheldon (1987), the role of herbivory in freshwater communities is less well documented. An example of the complex effects of changes in water level and muskrat activity producing variations in the floristic composition of vegetation in Eagle Lake, Iowa, was given by van der Valk (1981). Studies reviewed suggest that the mechanisms by which herbivory may influence plant communities are fundamentally similar for terrestrial, fresh water and marine ecosystems (Huntley 1991).

It is generally acknowledged that selective herbivory does not eliminate the species consumed from a given assemblage because the interdependence between the prey and its predator is too great. On the other hand, an increase in the herbivore population feeding on different plants may involve the decline of certain species in a particular assemblage (Crawley 1983).

There are many animals (insects, snails, fish, birds, mammals) which feed on pleustonic plants and also use them in other ways. The author is unaware of any papers dealing with the quantitative effect of the activities of herbivorous organisms on pleustonic plants. There is, however, a series of articles concerning this problem in qualitative terms. They were assembled, among others, by Sculthorpe (1969) and Landolt (1986). In the light of these it seems probable that herbivorous animals may exert some influence on quantitative relationships among pleustonic species and, in some circumstances, on the species composition of particular pleustonic assemblages (Landolt & Zarzycki 1994). The latter case may be illustrated with the help of a ducks-lemnid relationship. As was observed by Wolny (1956), a flock of ducks, amounting to 200–300 birds per hectare of a fish-pond, completely destroyed populations of *Salvinia natans* and *Lemna minor* pre-

viously occurring in this pond. In spite of this, the growth of *Riccia fluitans* and *Ricciocarpos natans* was unaffected by these waterfowl. It is difficult to explain this phenomenon; the author made no attempt to do so. It seems it might result from non-selective herbivory as mentioned above.

To sum up, the results obtained up to now on interspecific competition, allelopathy and herbivory (suspected to be important in structuring plant communities) suggest that these interactions are not responsible for the species composition in pleustonic assemblages.

5.3. Species co-occurrence patterns in pleustonic assemblages are random

The observed frequency distribution of k-species combinations follows a binomial distribution

In ecology, dispersion is conventionally classified into three categories; the frequency distribution pattern may be random, uniform (regular), or clumped (contagious). If organisms disperse completely randomly, their frequency distribution should be binomial (Okubo 1980). The concept of a random distribution implies that each of the elements (e.g. organisms or species) making up the population or assemblage, is located independently of all the others, so that any element has an equal and independent chance of occurring at any site.

The results obtained suggest also that a given pleustonic assemblage, realized under a particular combination of environmental factors, can be interpreted as a sample which forms an element in a binomial process, i.e. that this assemblage can be regarded as a random sample taken from the species pool typically associated with this combination of factors. In other words, we can conclude that pleustonic species are randomly distributed throughout the stands (=relevés) and their absence from any stand can be attributed to their rarity in the species pool. This binomial characteristic of the community assembly adequately explains the patterns of floristic composition in pleustonic assemblages found in the field. In this respect, the present results correspond with previous ones (Wolek 1983). Wolek and Pancer-Kotejowa (1988) came to the same conclusions when studying co-occurrence of *Luzula* species in Poland.

The fact that a pleustonic assemblage does fit a binomial distribution is, of course, no real guarantee that the assemblage is random. After accepting the null hypothesis that no difference exists between the observed distribution and the expected or binomial one, we must conclude that the combinations (=assemblages) of pleustonic species are structured according to a binomial process (=randomly). This should be considered true until new findings compel us to reject the null hypothesis in favour of the alternative one.

Some authors are of the opinion that the hypothesis that the number of species per locality follows a binomial distribution is seldom worth testing. This important question is discussed in Appendix I.

The observed frequency distribution of the k-species combinations and the frequency of occurrence of the individual species combinations follow the null model expectations

A satisfactory fit of the observed frequency distribution of the pleustonic species combinations (=pleustonic assemblages) to the expected one, under the null model assumptions, was observed in almost every case considered. The results obtained are in

close agreement with those found in the course of hypothesis testing for the binomial distribution. Exceptions in this respect are the results obtained for the subsets *Total/Ph*, *Total/Ph+Ma* and to some degree for the subset *Total/Ma*. It is suggested that this outcome might result from the fact that in nature there are different pools of pleustonic species, characteristic of different combinations of ecological factors, represented here by the combinations of water body type with vegetation type (section 4.3.2). Further evidence, presented in section 5.2, supports this suggestion; at present, it seems to provide the best explanation of the results obtained for the subsets in question.

Pleustonic assemblages and the equilibrium/non-equilibrium continuum

As far as pleustonic assemblages are concerned, the present results, obtained by stochastic simulation under null model assumptions, seem to support Gleason's (1926) view that plant patches are assemblages of individual, independent species, occurring in all possible combinations – “an association is merely coincidence”. The results obtained are compatible with his model according to which the presence of individual species is determined primarily by dispersal and habitat. There is no evidence that pleustonic assemblages are tightly structured. On the contrary, their internal structure seems far from being in equilibrium. It reflects the non-interactive responses of the component species to rapidly changing conditions in inherently unstable environments. In this respect, these conclusions concerning the dynamics of pleustonic assemblages correspond closely with the generalizations made by van der Valk (1987) about wetland vegetation dynamics.

The community structure determined by dispersal and the physical environment (as is the case in pleustonic assemblages) is considered to be the weakest possible structure. The implication is that communities of such a kind contain all those species which satisfy the following two conditions: (1) individuals of the species must have arrived at the site in sufficient numbers to settle and (2) they can live under the physical conditions of the site (Wiens 1984; Roughgarden & Diamond 1986; Moravec 1989).

According to some authors (Wiens 1984; Chesson & Case 1986; DeAngelis & Waterhous 1987; Giller & Gee 1987) natural communities should be viewed as being arranged along a gradient of states ranging from equilibrium to non-equilibrium (equilibrium/nonequilibrium continuum). Based on Wiens's (1984) proposition, pleustonic assemblages are here considered as assemblages occurring at the non-equilibrium end of the continuum. This requires: (1) a general “decoupling” of close biotic interactions; (2) the independent response of species to environmental changes; (3) a more or less opportunistic exploitation of resources by individuals; (4) a significant response by the assemblage to stochastic environmental effects, to mention only some of the features specified by Wiens (1984).

The contributions of the deterministic and stochastic components in determining the structure of a pleustonic assemblage are discussed below.

The community assembly in pleustonic assemblages

The results obtained by stochastic simulations under null model assumptions have revealed the existence of different pools of pleustonic species for particular habitats

settled by lemnids and which are characterized by the combination of water body and vegetation types. Taking this outcome into account, three main stages may be distinguished within the process of events leading to the assembly of a particular pleustonic assemblage.

(1) **Formation of the total species pool** sensu Keddy (1990, 1992). The pool is formed by including from the regional flora all pleustonic species occurring in Poland. In our case, the pool embraces nine species. If newer observational data had been used, the total pool would have included ten pleustonic species as *Lemna turionifera* Landolt has become a new element in the Polish flora (Wolff & Landolt 1994). The total species pool (called hereafter the *regional species pool*; the sense of the term differs from the one used by Pärtel *et al.* 1996) decides whether a species is available as an immigrant and hence as a potential member of the assemblage (or community) or not. The species composition of the pool is determined by the history of the flora and the climatic conditions in the particular region.

(2) **Formation of the final species pool.** Specific environmental factors determine which subset of pleustonic species in the regional pool will tolerate local conditions characterized by the combination of water body and vegetation types. The content of the final pool, selected by environmental filters (=assembly rules), is determined by the particular habitat type as specified above. Within each habitat type individual species combinations or pleustonic assemblages are realized by means of random events (third stage of the community assembly, for details see below). So, in any individual case, the final pool is not the set of species present in the community as proposed by Keddy (1990, 1992).

The mechanisms responsible for the content final pools are (i) dispersal and (ii) environmental abiotic factors represented by the water body type and vegetation type inhabited by the pleustonic plants. It seems that abiotic factors or their combinations, acting as environmental filters, principally determine the presence or absence of particular species and thereby the species composition of an assemblage. They can therefore be regarded as assembly rules. Dispersal appears not to be a real constraint for pleustonic species within the area studied.

It is claimed that assembly rules have a strong historical component so rules are dependent on context. Some experimental studies have shown that different sequences of invasion, due to priority effects, produced communities consisting of different species (e.g. Drake 1990 and references cited therein). The results of laboratory work carried out by Wolek (1979) are consistent with the above; they suggest that the sequential occupation of a site may be important in determining the species composition of pleustonic assemblages due to the inhibitive action of plants on one another caused by allelopathy. However, the results derived from observational and simulation data seem to indicate that, in nature, because of strong environmental fluctuations affecting the community assembly in lemnids, the order of settlement is not decisive either in the formation of the final pool or in pleustonic assemblage generation (see below).

The aspect of community assembly being discussed here is deterministic. It is very probable, however, that on account of the strong non-linear component present in the ecological systems under discussion, this aspect of the community assembly will dis-

play features of deterministic chaos, one of which is a property called *sensitivity to initial conditions*. By this is meant that if chaotic fluctuations of dynamical systems (e.g. plant populations) are recorded with time, and these systems start with similar (not the same!) initial conditions, even minute differences between these conditions are amplified, so aspects of the systems which were initially closely similar diverge from one another with extreme rapidity. Hence, the dynamics of the system cannot be predicted for more than a short time (Shaffer 1987; Ferrire & Fox 1995; Stone & Ezrati 1996). Possible sources of uncertainty in predicting the behaviour of a natural system are, among others, errors associated with making measurements, and fluctuations associated with unpredictable environmental changes from year to year (Suighara & May 1990). This property of deterministic chaos is known as the *Butterfly Effect* (a term coined by Lorenz 1963). However, this property with respect to an ecological system had been anticipated by Gleason (1939) who reiterated that differences in a series of communities cumulate with distance "... so that the ends of the series may be strikingly different, although connected by imperceptible or apparently negligible intermediates".

Owing to the sensitive dependence of a system on initial conditions, the species composition of the final pool determined by the ecological system may be difficult or even impossible to predict.

(3) **Formation of particular pleustonic assemblages.** Because pleustonic species are randomly and independently distributed within a particular habitat type, the frequencies of occurrence of the species expressed as probabilities can be used to make predictions about species combinations (=pleustonic assemblages) in terms of the theory of probability. Hence, this aspect of community assembly is regarded here as stochastic and as such is not governed by assembly rules. The general conclusion drawn from the above is that the community assembly may have not only a deterministic but also a strong stochastic component, and in this respect the conclusion corresponds with that arrived at by Weiher and Keddy (1995a).

The outline of the community assembly presented above corresponds with the situation revealed by Adersen (1988) in the Galápagos. He found that the diversity of pteridophyte species was governed on a global scale by general area-diversity patterns, and random distribution inside the archipelago. It explains also, why the first attempt at searching for patterns in pleustonic assemblages with the aid of the null model approach (Wolek 1983) was only partially successful in interpreting the results obtained.

Community/continuum controversy

It has been claimed that species are relatively rarely randomly distributed even within small and apparently homogeneous areas (Greig-Smith 1979). As was pointed out by Bouxin and Gautier (1982), out of 289 causes only 32 (i.e. 11%) were random. Weiher and Keddy (1995b) reviewed ecological works from this point of view and found that "it is time to conclude that in some places at some times with some taxa non-random communities exist". On the other hand, although there is now ample evidence that many communities are structured into predictable species sets, there is also evidence that other communities are not (Cody 1989). Therefore, paraphrasing Weiher and Keddy's (1995b)

sentence, it may be said that it is time to conclude that in some places at some times with some taxa non-random communities do indeed not exist. What is more, it becomes evident that assemblages may rank along a Clements/Gleason axis with respect to their degree of internal organization (see also Roberts 1987; Cody 1989). From the latter, the perspective emerges that every community may have a unique structure determined by one or more environmental factors. The ecological dominance of some of them may change in time in the same place. This is probably the reason why, in nature, evidence for both points of view (assenting to the community or continuum hypothesis) may be found. The author's own results, for example, have supported the individualistic hypothesis and in this respect they correspond with those of others (Matuszkiewicz 1947, 1948; Wilson 1988; Adersen 1988; Wilson & Allen 1990; Wilson *et al.* 1992; Fernandez-Palacios & Anderson 1993; Auerbach & Shmida 1993, to cite only some) but there are many papers that have come to different conclusions (e.g. Glavac *et al.* 1992; McIntosh 1993 and references cited therein); ample evidence exists supporting either the community-unit or the individualistic hypothesis.

The persistence of these differences concerning vegetation communities may suggest that: (1) clarification of the theories is needed (McIntosh 1993), (2) the community/continuum controversy is illusory because both conditions depend on how one defines and observes a given vegetation system (Scott 1974; Allen *et al.* 1993) and (3) both community patterns, continuous and discontinuous, may exist in nature side by side (e.g. Westman 1983). What is more, Shipley and Keddy (1987) found that neither of the two usual hypotheses concerning vegetation communities explained patterns examined by them. They suggested, therefore, that the historical dichotomy was too limited and a multiple working hypothesis of community patterns should be considered. Most certainly, the perspective mentioned above may also be the reason why no single model adequately describes all communities, as has from time to time been reiterated by some authors (e.g. Giller & Gee 1987; Townsend 1989, acc. to Allan 1995).

It is concluded from the above, and especially from the perspective of the existence in nature of a gradient ranging between tightly (=Clementsian) and loosely structured (=Gleasonian) plant communities, that further insistence on testing the community and continuum hypotheses becomes an unnecessary waste of time. Theoretically, the existence of both kinds of community, Clementsian and Gleasonian, occurring at opposite ends of the gradient is decisive but, as indicated in the references cited in this section, we deal, as a rule, with intermediate entities in relation to their internal organization and therefore we fail to disprove either hypothesis. The concept of the Clementsian/Gleasonian continuum implies not only that more than the two traditionally accepted hypotheses of the vegetation community are possible but also that more hypotheses may exist than had been suspected by Shipley and Keddy (1987). Hence, for methodological reasons, every vegetation entity should first be regarded as unique.

5.4. The syntaxonomy of pleustonic plant communities

Syntaxonomy: some methodological remarks

The recurrence of certain species combinations and the existence of persistent species enable us to determine plant associations. It is assumed that both these attributes of a plant association are the product of a specific combination of abiotic and biotic environmental factors (Section 1.2). Such reasoning is a typical example of inferring mechanisms from observed patterns. As is known, however, the interdependence of a given mechanism and the pattern caused by it is not a specific relation; therefore, the mechanism cannot be inferred from the pattern (Anand 1994). It is easy to make out a case that the two features of plant communities, namely the recurrence of certain species combinations and the persistence of some species, can be explained by merely assuming that unequiprobable species (=species of different degrees of rarity) distribute themselves independently and randomly within a homogeneous environment. An illustrative example is given in Table 28. As can be seen, some species combinations occur very often (i.e. the condition *recurrence* is met), whereas others are very rare or even absent. With a sufficiently large species pool and very different proportions of species in the pool, this phenomenon is very clear (for other examples of this phenomenon see Wolek 1983; Wolek & Pancer-Kotejowa 1989). A closer examination of the species composition of the individual combinations presented in Table 28 reveals also that there is a group of species constantly occurring in the majority of combinations (i.e. the condition *persistence* is met), and a second group embracing species encountered sporadically. These can be designated a group of accidental species. Whether a particular species will occur in many species combinations or only a few depends on the frequency probability of its occurrence in the species pool, i.e. the more common species will appear more often than rare ones (Wolek 1983, 1988). If now, using the Braun-Blanquet method, we “make relevés” of null communities (“stands”), represented by horizontal shading in Table 28, and omit null communities consisting of 1 species as well as “stands”, the occurrence frequencies of which are very small, we shall obtain distinct “plant associations” with characteristic species combinations. The lack of some species from the combinations created, or “species associations”, can be explained (successfully!) with the help of the competitive exclusion principle. We can also involve many other mechanisms; in this respect see the list of 120 hypotheses explaining the coexistence of species (Palmer 1994).

The conclusion which results from the above is that if only those species combinations which are most frequently encountered in the field (i.e. part only of the whole variability range) are considered, then the suspicion arises that similar groups of species which occur repeatedly in the field are the result of recurring similar or identical combinations of abiotic and biotic factors. This may be so but, as the above hypothetical example demonstrates, is not necessarily the case.

Pleustonic plant associations: fact or fiction?

Almost all the results obtained suggest that the floristic composition of a given pleustonic assemblage is determined by a combination of deterministic abiotic factors and

Table 28. The frequencies of occurrence of the different possible species combinations generated under the null model assumptions. The proportions of 9 hypothetical species in the pool were calculated arbitrarily. For explanations see text.

Combinations	Species									<i>f</i>
	1	2	3	4	5	6	7	8	9	
1-species	+									75
		+								6
			+							7
				+						11
							+			-
								+		-
2-species	+	+								28
	+		+							30
	+			+						37
	+						+			1
	+							+		2
	+								+	2
		+	+							4
			+		+					7
			+			+				-
				+	+					6
3-species	+	+	+							15
	+	+		+						24
	+	+			+					1
	+	+				+				1
	+	+							+	1
	+		+	+						20
	+		+		+					2
	+		+			+				1
	+		+					+		1
	+		+						+	2
+						+		+	1	
4-species	+	+	+	+						20
	+	+	+		+					2
	+	+			+			+		-
	+	+						+	+	1
	+	+		+					+	2
	+		+	+	+					1
5-species	+		+	+	+					1
	+	+	+	+	+					2
	+	+	+					+	+	-

random events, and species interactions have no impact on community patterns. This means that the assemblages of pleustonic species under consideration may be treated as but random subsets of final species pools. It is worth emphasizing here that these results

are in close agreement with those obtained by Haila (1983) who examined island colonization by northern land birds.

The above finding supports the view that the syntaxonomy of pleustonic associations based on a floristic criterion must fail for just the reason mentioned above. It seems obvious that the overwhelming importance of chance in determining the species composition of particular pleustonic assemblages is essentially due to the fact that these assemblages are not persistent either in time or space. Ignoring for a moment the seasonal changes observed in the species composition of pleustonic assemblages, it can be said that under temperate climatic conditions they meet their end in autumn. The component species develop resting forms, turions and spores, which enable them to survive unfavourable conditions during the winter. These resting forms germinate in spring and a fresh pleustonic assemblage may develop. Pleustonic assemblages occur, as a rule, in ecologically unstable environments. They are composed of free-floating plants and are therefore sensitive to the destructive motion of water and wind. It seems, then, that the reasons given here are sufficient to explain the failure of any attempt at a phytosociological classification of pleustonic associations, based on any floristic criterion.

Species composition patterns following both the binomial distribution and null model expectations have been found in non-autonomous synusiae. It may be argued that this outcome results from the fact that pleustonic species inhabiting aquatic and helophytic communities usually occur in low abundance. As a consequence, biotic interactions (i.e. interspecific competition and allelopathy) do not influence the species composition of pleustonic assemblages and, therefore, discontinuities in non-autonomous synusiae have not been found; they would surely have been observed if pleustonic assemblages consisted of abundant species closely covering the water surface as in the case of pleustonic phytocoenoses. The possibility, of course, cannot be completely ignored and should be examined in detail by means of appropriate experiments. At the moment, however, we do have indirect evidence which may be used to support the results obtained in this study. This unintended support is given by Landolt and Zarzycki (1994). These authors investigated lemniids in Argentina. They came to the conclusion that there are some pleustonic communities having their own characteristic species combinations, observations supported by chemical water analyses. However, some remarks they made in their paper contradict the conclusion mentioned above. On the contrary though, these observations correspond with the results obtained by the present author. The relevant sentences are as follows (the heavy type is mine): "... the selection of the investigated waters was not purely accidental. ... waters with a **closed cover** (containing more than one or two species) were preferred. ... Since the statistical evaluation did not reveal an ordination useful for sociological units, the ordination was made by hand after having divided the samples in three groups according to predominance of the three *Lemna* species: *L. gibba*, *L. minuta*, *L. aequinoctialis*. ... The three **distinct** pleustonic communities ... are connected by many **transitions**. ... Whether the three communities can be divided into subunits is difficult to decide. ... Some plant sociologists may divide the community into many lower units. However, it would be difficult to clearly distinguish defined associations because the stands change their species composition throughout the year, and the

presence of one species or another might well be incidental and temporary” (p. 73). The above can also serve as an excellent illustration of some observations made by the present author, concerning the phytosociological method of searching for patterns in lemnids in particular and in vegetation communities in general.

Sometimes (information from the author’s personal experience) it is argued that random components play an important role, but only in the formation of pleustonic assemblages that are unique with respect to their mobile and transient character. The significance of the stochastic factor decreases in favour of deterministic mechanisms, especially interspecific interactions, in the case of terrestrial vegetation communities. Results published recently by some authors (e.g. Weiher & Keddy 1995a; Klötzli 1995 and other references cited in Section 5.3) do not support this view. Klötzli (1995), for instance, investigated changes in forest and grassland plant communities. The evaluation of sets of data for four long-term permanent plots in different more or less stable plant communities showed, among other things, that changes in species composition, species function (e.g. generalists vs specialists, common vs rare species) and species abundance, which occurred from year to year, were unpredictable and probably chaotic. Whereas, in true succession, where changes in a given site proceed in a particular direction, populations of many of the species examined behaved “like clouds moving deliberately and in many ways over a given surface”. According to Klötzli (1995), these findings seem to call into question the importance of the relevé as evidence in support of the characteristic species combination of a particular plant community, which may only be “a flash in the existence of a fluctuating ecosystem”.

A great many different phytosociological classifications of pleustonic associations have been proposed (see Section 1.3) and different syntaxonomical schemes are used by different phytosociologists. It is common practice also to delimit pleustonic associations with the aid of a combination of various phytosociological classifications. It is an unreasonable procedure because, in this way, certain parts of a particular phytosociological system are mechanically combined with others that originate from other syntaxonomic systems. Activity such as the creation of more and more new phytosociological classifications, recognizing more and more new pleustonic associations, changing the limits of syntaxonomic diagnoses, already emphasized by den Hartog (1978), appears to be an obstinate manifestation of juggling. I am afraid that such an approach cannot solve the syntaxonomic problems of pleustonic assemblages in particular and plant communities in general.

In phytosociology, for some time past, the tendency has been to delimit pleustonic, aquatic and helophytic plant associations with the aid of dominant species (Tomaszewicz 1980; Matuszkiewicz 1981; Rejewski 1981) and this may be a provisional solution to the dilemma in question. However, as has been pointed out earlier (Wołek 1974b), a syntaxon distinguished in this way differs essentially from an association which, following Braun-Blanquet (1932), has been defined by means of a characteristic combination of plant species. If the species composition of a plant assemblage is determined mainly by the physical environment and random events, as is the case with pleustonic assemblages, then it is difficult, of course, to speak about a characteristic species combination in the Braun-Blanquet sense. It seems, therefore, that the delimitation of an ecological group of

pleustonic species (=final pool), characteristic of a particular habitat type as defined in this study by means of the combination of water body and vegetation types, might be more reasonable. Within a particular habitat type, pleustonic assemblages should be considered in terms of species combinations, where necessary.

APPENDICES

APPENDIX A: **Community or assemblage**

The “definition and delineation of the community have been the despair of many ecologists” (McIntosh 1993), but, before we can begin any ecological study, we must first have an adequate community definition (Austin 1985; Magurran 1988; Drake 1990). Much present ecological work is conducted as though communities exist, but the term community is rarely defined. Even when it is, the definition is likely to differ in various ways from others, reflecting the general lack of agreement over what exactly constitutes a community. In addition, most ecologists use the term community in a very vague sense (Austin 1986, 1990; Moulton & Pimm 1986; Roughgarden & Diamond 1986; McIntosh 1993).

Communities may be defined by their organization (organizational definition) or by their occupation of a location (locational definition). Clements’s definition of a plant association is an example of an organizational definition, and Gleason’s a locational one (Southwood 1987). Some examples of locational and organizational (i.e. trophic, taxonomic, life form) definitions used in the ecological literature are given by Giller and Gee (1987). In addition see Roughgarden and Diamond (1986).

Generally speaking, the term *community* is reserved for a set of organisms which are assumed to be integrated by biotic interactions (Caswell 1976; Underwood 1986; O’Connor 1987; Southwood 1987; Grubb 1987; Barkman 1990; McIntosh 1993). Many variants of the “core definition” exist in the ecological literature, among which is a curious one by MacArthur (1971) who defines the community as “any set of organisms currently living near each other and about which it is interesting to talk.”

Various community components (e.g. guilds, trophic levels, taxocenes, locations, etc.) are studied under the guise of communities. It is scarcely surprising then that comparative analysis using such broadly as well as narrowly defined communities are of limited value (Moulton & Pimm 1986; Drake 1990). Drake (1990, 1991) called, therefore, for the study of entire communities rather than their components.

Ecologists have long maintained that, at levels of organization above the single individual, the whole is more than a sum of its parts. That is, as components combine to produce larger and more complex systems, new properties, so-called *emergent properties*, appear that cannot be derived from the properties of the individual components (Odum 1986). In practice, there is little agreement as to which properties of plant communities are emergent and which only represent the sum of the properties of these individual components and should therefore be termed *collective properties* (Moravec 1989, for details see Salt 1979; Edson *et al.* 1981; Underwood 1986; Cole 1991; Gordon 1991).

Indeed, as Roughgarden and Diamond (1986) note, it is not obvious whether there is any level of organization above the single individual at all.

In this context, descriptor *assemblage* seems the most appropriate term for a set of organisms whose degree of organization is unknown (Giller & Gee 1987). So *assemblage* means a group of species in combination in a location about which no assumption of biotic interactions among them is made. What kind of interactions are important, and to what extent, has to be discovered, but not assumed *a priori* (O'Connor 1987; Southwood 1987; Wolda 1987; Wiegleb 1989; McIntosh 1993). It is assumed here that only structural relationships make a species assemblage a community. This idea was developed by Moravec (1989) who has theoretically distinguished three main kinds of plant assemblage characterized by different degrees of integration.

It is worth noting here that the extreme opinion held by some scientists that communities are merely random assemblages of individualistic and independent species, occurring in all possible combinations, implies that plant communities as well as vegetation science do not exist (Barkman 1990). The question of the reality of communities and other related problems have recently been discussed in detail (Wilson 1991, 1994; Keddy 1993; Palmer & White 1994; Mirkin 1994; Dale 1994).

In this paper, the groups of pleustonic plants (=combinations of pleustonic plants) under study will be termed assemblages for the reasons mentioned above, until we obtain results which force us to recognize these groups as communities. This would seem to be a sound approach from the methodological point of view.

In the context of any phytosociology, concrete and abstract units are identified by different terms, one of which is the term *community* defined in its various ways (Mueller-Dombois & Ellenberg 1974; van der Maarel 1975; Westhoff & van der Maarel 1978; Glavac *et al.* 1992). To avoid misunderstandings, a section of vegetation (concrete unit) will be referred to as a *phytocoenosis* or *stand* and a group of phytocoenoses (abstract unit) will be termed an *association*.

APPENDIX B: Pattern, process, mechanism

When analyzing observational data we inevitably deal with patterns. At present, many ecologists claim that searching for the patterns, defining the processes and isolating the mechanisms which direct and regulate these defined processes is the chief goal of community ecology (Anand 1994). The execution of this task, however, may appear somewhat difficult, because various definitions of pattern, process, mechanism and other relevant terms such as structure, arrangement, order and so on exist in the literature (e.g. Hutchinson 1953; Rejmánek 1977; Wiens 1984; Hogeweg *et al.* 1985; den Hartog & van der Velde 1988; Wiegleb 1989; Smallwood 1993; Anand 1994). For the purposes of this study the following definitions have been adopted.

Structure is defined here as any set of arranged elements (objects, events, properties, etc) and the relationships among them. *Arrangement* means the way in which the elements are placed in space and time. Following den Hartog and van der Velde (1988), one assumes that structure consists of three major components, namely: (1) composition (or

texture sensu Barkman 1979), i.e. the floristic composition of an assemblage in a qualitative as well as a quantitative sense; (2) arrangement of individuals in space and time; and (3) relations among individuals and between them and the surrounding biotic and abiotic environment. A characteristic recurrent and recognizable arrangement of the elements is termed a *pattern*. In a broader sense, each characteristic, recurrent (ecological, biogeographical, or phytosociological) structure is termed a pattern.

Two kinds of pattern can be distinguished: (1) a pattern in a space, and (2) a pattern in time, also called a *process*. *Temporal patterns* are revealed when areas are observed repeatedly over time (Anand 1994). In other words, a process is the difference observed in a unit between two times of observation (Wiegleb 1989). In this context, a process can be defined as a continuous change of a spatial pattern over time. Such a process has a beginning in time (an initial spatial pattern), a series of intermediate stages and a completion (an end or final spatial pattern) when the process, theoretically, stops. In ecology, temporal patterns or processes have generally been termed *successions* (Anand 1994). Following den Hartog and van der Velde (1988), a *spatial pattern* can be divided into: (1) horizontal patterns (e.g. random, clumped or uniform), (2) vertical patterns (i.e. zonation and stratification), and (3) three-dimensional pattern or architecture, defined as the way in which the community fills up the available space.

Anand (1994) describes as follows the relations connecting pattern, process and mechanism. Patterns are what we perceive. Processes describe how these patterns come about and how individuals and species are combined. Mechanisms provide explanations as to why these patterns occur and are the causes of change in vegetation patterns. Mechanisms direct and regulate community processes.

Because process is defined as the set of patterns observed in time (or the set of changes in a pattern in time) in a given site, it cannot explain the pattern. Neither can it determine the pattern. Strictly speaking, the temporal pattern does not explain the spatial pattern. It is only the mechanism underlying the patterns in space and time that can explain both kinds of pattern (for details see below). However, as has been emphasized by Anand (1994), the terms *process* and *mechanism* are often interchanged and thereby incorrectly used; e.g. competition has been regarded both as a mechanism (Drake 1990) and a process (Cale *et al.* 1989; Drake 1990), to give only one example. This practice results most probably from the fact that some authors do not follow strict scientific definitions of these terms but use them in their unclear colloquial sense. Therefore, to avoid any misunderstanding, in the present paper the term *process* is used solely to define a series of events, operations or actions responsible for any change in community structure.

Mechanism is defined here as a chain or series of events, created by definite abiotic and/or biotic factors (=causes), as a result of which definite spatial and temporal patterns come into being. The kinds of events and the order in which they occur, may be of great importance in the formation of both types of pattern. A specific mechanism can be part of a process in its sense as a series of events (see above). Mechanisms generate and maintain spatial patterns in plant communities. They also produce, direct and regulate temporal patterns. Without a knowledge of the underlying mechanisms, spatial and temporal patterns cannot be understood.

APPENDIX C: Assembly rules

The existence of regularities or non-random patterns in ecological communities suggests that there are certain constraints that determine which species can and which species cannot occur together. These constraints were formerly called *laws* but in modern ecology they are termed *rules* (McIntosh 1993). Already by the early twenties, Ramensky (1924, acc. to Whittaker 1962), one of the originators of the individualistic concept, was arguing that, because of the kaleidoscopic spatial composition of plant communities, it is not community units but the rules of plant combination which are important. However, the search for regularities in nature and for rules generating them, dates back only to Diamond (1975) who proposed the term *assembly rules* when investigating how different assemblages of island birds come into existence from a common species pool. Thereafter, one of the important goals of community ecology was to determine the assembly rules that enable species to coexist.

It is often stressed that merely demonstrating that a non-random pattern exists provides no evidence for the existence of assembly rules. The term should therefore be reserved for those constraints that actually govern the community pattern and can be used to predict it (Weiher & Keddy 1995b). On the other hand, some authors claim that any evidence must be indirect, based on an interpretation of non-random patterns in terms of assembly rules. As a result of this, the available evidence is dubious, especially for plant communities (Wilson & Whittaker 1995 and references cited therein).

Different definitions of assembly rules have been proposed (Diamond 1975; Brown 1987; Fox 1987; Wilson 1989, 1991; Drake 1990; Keddy 1990, 1992; Fox & Brown 1993, 1995; Weiher & Keddy 1995b; Wilson & Gitay 1995; Wilson & Whittaker 1995). In general, two kinds of assembly rule are distinguished at present: *species-specific* (Diamond 1975; Wilson 1989, 1991) and *functional* or *guild-specific* (Fox 1987; Fox & Brown 1993, 1995). In the first case, based on co-occurrence frequencies, certain combinations of species are inferred to be either forbidden or permissible. In the second case, the assembly rule specifies the functional group from which the species should come, rather than specifying the individual species in the assemblage (Fox & Brown 1993). Whether species or functional group is the best starting point for assembly rules is considered by Keddy (1992). Different kinds of rule have also been proposed: capacity and allocation rules (Brown 1987), assembly and response rules (Keddy 1990, 1992) and chaotic assembly rules (Drake 1991).

Some authors (Lawton 1987; Wilson & Whittaker 1995; Wilson & Gitay 1995) have regarded species interaction, mainly interspecific competition, as an assembly rule in itself. Others (Keddy 1990, 1992; Weiher & Keddy 1995b) have considered all environmental factors, abiotic and biotic, as assembly rules. According to Keddy (1992), specific environmental factors may act as filters selecting subsets of species with characteristics appropriate to a particular type of habitat, and power community assembly processes. In this way, environmental filters or assembly rules are an analogue of natural selection at community level (Keddy 1992).

For the purposes of this study, the assembly rules as defined by Keddy (1990, 1992) have been adopted. They are considered here in terms of species presence and absence,

but at any time they can be transformed to become the assembly rules based on species traits as proposed by Keddy (1990, 1992) and Weiher and Keddy (1995b). These assembly rules determine which subset of species in the total species pool will tolerate the specific environmental conditions and form a community.

Mechanisms and processes, as defined above, are considered here as devices of assembly rules. For another view of this problem see Wilson (1989) and Drake (1990).

APPENDIX D: **Null model and null hypothesis**

The basic concept of community structure is that it is a structure generated by biological interactions, especially interspecific competition which is believed by some ecologists to be the basic organizing force in ecological communities. Hence, they invoke this interaction as an explanation for community patterns, e.g. for species composition. Other ecologists have argued, however, that, before we can explain community pattern in terms of the competitive exclusion principle, we must first of all find legitimate grounds for rejecting the null hypothesis of no competition. For this purpose it is necessary to compare an actual community pattern with a random one, generated under the assumption that the elements considered (e.g. species) occur randomly and independently of one another in space (i.e. in the absence of competition). Only when a such null hypothesis is rejected can we involve competition as an explanation of the real pattern. Models that predict patterns of species distribution in the absence of competition are called *null models*. Sometimes the term *neutral model* is used (Caswell 1976).

Null models were introduced into ecology among others by Williams (1947, 1951, 1964) and Cole (1951) (for details see Strong 1980; Järvinen 1982; May 1984), but in fact the development of the models in community ecology has progressed rapidly only since the papers by Caswell (1976) and especially Connor and Simberloff (1979) who made an attempt to examine the so-called *assembly rules* proposed by Diamond (1975) for avian species on islands in an archipelago. They maintained that field data on species distribution were quite compatible with the null hypothesis that avian species colonize islands randomly and independently with no species interactions. Their paper aroused intense controversy concerning the construction of null models to detect a departure from a random expectation, the methodological grounds for the application of a null hypothesis in ecological and evolutionary studies, as well as its usefulness in these studies at all. Discussion of these issues and recent developments in the null model/hypothesis problem can be found in papers by Connor and Simberloff (1979, 1983, 1986), Simberloff and Connor (1979, 1981), Grant and Abbott (1980), Diamond and Gilpin (1982), Gilpin and Diamond (1982, 1987), Harvey *et al.* (1983), Quinn and Dunham (1983), Roughgarden (1983), Simberloff (1983), Strong (1983), Wright and Biehl (1983), Strong *et al.* (1984), Wilson (1987, 1995), Wołek (1988a), Roberts and Stone (1990), Stone and Roberts (1990), Jackson *et al.* (1992), Silvertown and Wilson (1994).

At least part of the controversy has been due to the use of *null hypothesis* as a synonym for (1) *null model* and (2) *null hypothesis* in the statistical sense. It seems, therefore, necessary to distinguish these terms (Wołek 1988; Scheiner 1993).

(1) The term *hypothesis* is a scientific assumption which is suggested as a possible explanation for a particular phenomenon. *Model* in this context is a tool. It can be defined here as a theoretical description of an ecological system. This description contains the list of conditions or assumptions under which the system acts. Examination of the model makes it possible to assess the validity of the hypothesis under consideration. As is evident from the above, the two terms are by no means synonymous.

(2) Three kinds of hypothesis, research, alternative and null, are distinguished in statistics (Siegel 1956). The *research hypothesis* is the prediction derived from the theory under test. To test this research hypothesis one needs to state it in operational form as an *alternative hypothesis*, H_1 . Generally speaking, the alternative hypothesis is a hypothesis of difference. To test this alternative hypothesis we must falsify the so-called *null hypothesis*, i.e. a hypothesis of no difference, H_0 . If the data permit us to reject H_0 , then H_1 can be accepted, and this would support the research hypothesis and its underlying theory.

The null hypothesis, as usually used in ecology, is not a null hypothesis in the strict statistical sense (i.e. it is not stated in an operational form) but takes the form of a research hypothesis; for example, "... a null hypothesis posits that species do not affect one another's geographical distributions, and the alternative hypothesis is that certain species exclude one another..." (Connor & Simberloff 1986: 160). For other examples see e.g. Wilson and Whittaker (1995: 801) and Kitayama and Mueller-Dombois (1995: 667/668). As is seen from this example, the research hypothesis in ecology is stated in *null* and *alternative* forms. In order to avoid misunderstandings it would be useful, therefore, to distinguish *research alternative hypothesis* and *research null hypothesis* from their statistical operational forms – alternative and null hypothesis.

In the light of the above, the strategy of using null models in ecology will first of all depend on defining exactly the two research hypotheses and their operational forms, as well as on the data used, experimental or observational.

In the first case (experimental data), we can state the alternative and null hypotheses concerning a single factor X and can construct the null model to test for the effect of X . Such a model will comprise all the important biotic and abiotic factors that could affect the observed data except X itself. It must be stressed here that it is only possible to construct such a null model in an experimental approach where the model really is null with respect to the posited factor because it does not contain it. Hence, the null hypothesis, used in the two senses, research and statistical, has logical primacy.

In the second case, if observational data are used, it is impossible to construct a null model as presented above because the effect of a single factor X cannot be excluded from it. Although null models based on observational data cannot be used to test for the effect of a single factor, they can be applied to determine if a pattern exists (Roughgarden 1983). The statistical null hypothesis that a pattern observed in an ecological community (e.g. the pattern of species composition) is random is falsified against the alternative hypothesis that it is not.

In any approach that accepts observational data as the basis for testing the research hypothesis, the entire set of factors competing for a place in the explanation of the observed pattern must be eliminated from the null model; it is assumed therefore that

events (e.g. species) occur randomly and independently of one another in space. The ecological implication of this assumption for the community pattern examined is that the species in the community neither interact biotically nor differ in intrinsic characteristics such as their response to abiotic factors (Caswell 1976).

Comparison of the model's predicted random pattern with the actual pattern observed allows us to assess the validity of the null hypothesis. If this hypothesis cannot be rejected, we must conclude that evidence of a non-random pattern is not provided by the data at hand; it is conceivable that alternative evidence, obtained from another data sample, would have led to the rejection of the null hypothesis. If it is rejected this does not mean that a particular ecological factor (e.g. competition) is responsible for the pattern under examination. In a test of the goodness-of-fit type, as considered here, the alternative hypothesis is always composite and such a conclusion cannot be drawn. One may only interpret the result as indicating that some organizational ecological factors exist in the community under examination. To identify these factors, further investigations must be carried out with the help of manipulative experiments (see also Caswell 1976; Shipley & Keddy 1987).

Although the null model based on observational data cannot be used to test for the effect of a single factor (Caswell 1976; Colwell & Winkler 1984; Gilpin & Diamond 1984, see also Connor & Simberloff 1979, 1984), the direction of the deviation from randomness can, however, suggest research hypotheses about the putative ecological factors underlying the observed pattern (Caswell 1976; Connor & Simberloff 1983; Jackson *et al.* 1992; Palmer & van der Maarel 1995). That is, if an actual species composition occurs more frequently than expected under the null model assumptions this may indicate either facilitation (positive interaction) and/or a common response to environmental factors. On the contrary, if the actual species combination occurs more rarely than that predicted by the null model, then we may conclude this to be the result of negative interactions (e.g. interspecific competition).

It seems logical, from the above, that all hypothesis testing should begin with a simple null hypothesis because (1) one cannot invoke a particular ecological factor as the explanation for an actual community pattern before establishing that this factor really does exist and (2) one cannot start to explain a community pattern if there is no evidence that the pattern really does (i.e. in a statistical sense) exist at all.

APPENDIX E: **Chance and randomness**

Chance and *random* are terms that take a variety of meanings in ecology (e.g. van Valen 1982; Wimsat 1982; Schoener 1986; Noy-Meir & van der Maarel 1987; Crawley 1989b; Wiegleb 1989). To avoid misunderstandings, there is a need to define these and related terms. At first, following Kendall and Buckland (1960), we must define the terms *variable* and *variate*.

In the mathematical sense, a variable is a quantity which may take any of a specified set of values. On the other hand, a variate or random variable, a term characteristic of probability theory, is a quantity which, like a variable, may take any of the values of a

specified set but with a specified relative frequency or probability. That is, a variate is to be regarded as defined not merely by a set of permissible values, like a mathematical variable, but also by an associated probability function expressing how often these values appear in the situation under consideration. Hence, the phrase *random event* means an event with a probability of occurrence determined by some probability distribution; *random (=stochastic) process* is employed to denote a process in which is incorporated an element of randomness; and *random (=stochastic) variation* means variation in which at least one of the elements is a variate.

A probability distribution may be derived theoretically from a mathematical model or empirically from a frequency distribution. In the latter case, we must have at our disposal a sample of empirical data comprising recurrent events. Only in such a situation can we use the adjective *random*. It needs to be stated that randomness in nature, under discussion here, is sometimes confused with random sampling. The first is related to the independence of events in nature, the second to the sampling strategy used which is aimed at producing a truly representative subset of the events occurring in nature (Sokal & Rohlf 1981). If we are deal with non-recurrent events, which may, for example, be associated with severe climatic upheavals such as floods, droughts or fires, the term *chance* will be used. Thus, the phrase *chance (or episodic, accidental) events* will relate to these events which are unexpected, unusual or unpredictable in terms of probability, as opposed to random events. It is chance, for instance, that determines which species combination will have been realized at a given site and the result of such a single event cannot be predicted in any way. However, chance events considered *en masse* do obey stochastic laws and the event "occurrence of a definite species combination at this site" has an associated probability which can be estimated. So, randomness is seen as not haphazard, but possesses a statistical regularity of its own (Okubo 1980). It must be noted here, however, that the term *non-recurrent* should be understood as "non-recurrent in practice within the time scale under consideration", i.e. the events examined may be episodic in one time scale but random in another. It is also probable that non-recurrent events are generated by deterministic chaos. Distinguishing between random and chaotic events is useful in practice because, if a given system exhibits chaotic behaviour, short term predictions are possible (Stone & Ezrati 1996).

In the context of the above, we can speak of *demographic stochasticity (=randomness)* as opposed to *demographic chanciness* and of *environmental stochasticity (=randomness)* as opposed to *environmental chanciness*. For another view of this problem see Noy-Meir and van der Maarel (1987), Crawley (1989b) and Wiegleb (1989).

APPENDIX F: **Methodological framework for dealing with community assembly**

After delimiting and describing plant communities, phytosociologists focus their attention on those factors which can determine the observed floristic composition of the communities examined. Floristic differences found in stands are usually explained with the aid of abiotic and/or biotic factors. In the latter case this usually means by interspecific

competition. This approach is based on the tacit assumption that some deterministic environmental factors must be responsible for the floristic differences observed in the various stands. There is, however, no *a priori* reason to exclude random processes from the considerations. The only way to explain patterns observed in nature is to study all possible determinants of the ecological pattern under consideration, not just one arbitrarily chosen. In this section, a view will be set out relating to a framework within which community assembly may be studied.

Theoretically, two main strategies can be distinguished in the process of the creation of plant communities or phytocoenogenesis: (1) the species pool determines whether a species is available as an immigrant and whether in fact this species does establish at a site and enter a given assemblage and (2) the species pool determines only whether a species is available as an immigrant, whereas resource availability, abiotic factors and biotic interactions are the determinants of whether (i) this species will in fact establish and become a member of a given assemblage and (ii) this assemblage will change into a community.

With the first strategy, two different scenarios can be envisaged. The first assumes an ideal ecological situation in which propagules, produced by potentially available species, disperse independently and randomly, the initial conditions are maintained, all sites are equally available for all the species considered, and all species have identical requirements with regard to environmental factors. As a consequence, the species combinations will be formed randomly, according to probability theory. It means that the species producing many propagules will come into contact with one another more frequently than those producing fewer. According to the second scenario, some non-random patterns observed in nature may result from various random ecological processes.

By contrast, the second strategy leads to the conclusion that non-random patterns result from various non-random or deterministic ecological processes. A possible scenario for the assembly of plant communities, corresponding in general to the views of other authors (e.g. Gleason 1926; Braun-Blanquet 1932; Mason 1947; Stugren 1976; Collier *et al.* 1978), may be outlined as follows.

When a particular propagule enters a new area, environmental factors begin to affect it. These will determine which of the newly arrived propagules will establish and produce offspring. According to this view, physical and biotic factors act as a sieve or filter. Either directly or indirectly, they select subsets of species from the pool of available species, and thereby influence the community assembly. Thus, a large number of propagules may arrive, but because of environmental selection, only a few may establish at the site. It is believed that specific environmental factors will determine the presence or absence of particular species.

The concept of environmental filters has been employed recently by some authors (e.g. van der Valk 1981; Keddy 1992; Weiher & Keddy 1995a), but the idea of the environment acting as a sieve is certainly as old as ecology itself.

Habitat selection should be considered as a continuous process. The characteristics of environmental filters change hand in hand with habitat changes. These changes may result from physical changes and chemical reactions taking place in the habitat itself caused by the actions of the plants occurring there, including evolutionary changes in the plants

themselves. Step by step, when populations of plant species increase in size, the intensity of interactions within and among these populations will also increase. This statement is also true for plant-animal relations. Some types of specific interaction (e.g. mutualism, parasitism, predator-prey relationships) may emerge at the first stage of colonization of a particular area.

The pool of species available for inclusion in a given assemblage also changes as a result of the continual arrival of new species in the surrounding region and the extinction of species in the assemblage.

As the biotic relationships within a species assemblage increase, so it changes into a community or at least into an assemblage with some degree of integration. Communities can be characterized by their different degrees of integration depending on the strength and extent of the biotic relationships within them. The number of species with strong biological interactions is limited within any one kind of habitat (Christiansen & Fenchel 1977 acc. to Angelstam 1992). It is reasonable to expect, therefore, that any community will consist of small groups of species with strong interactions that coexist within groups consisting of a large number of species within which there are weak or no interactions (Angelstam 1992).

Several experimental studies have shown that altering the order of introduction of the species used to assemble communities can produce communities containing different sets of species (Drake 1990 and references cited therein). These results imply that a historical component or priority (=founder) effect can control the species composition in some types of community (Yodzis 1986).

When analyzing the species composition of a plant assemblage, one should take into account the fact that some aspects of community assembly can be deterministic and others stochastic (Weiher & Keddy 1995a). Therefore, random as well as abiotic and biotic assembly components should be considered during the course of the study.

Independently of any aspect examined within this framework, for reasons discussed elsewhere (Appendix D), the methodological principle was applied whereby random processes were considered first and then, if necessary, followed by deterministic ones (see also Wolek 1988).

APPENDIX G: Consequences of rejecting or accepting the null hypothesis

Both the failure to reject the null hypothesis for an independent and random dispersion and its rejection in favour of the alternative one, raise the question of what can be inferred from these decisions. All considerations relating to this problem focus, as a rule, on the first case, i.e. when the decision is made not to reject the null hypothesis. It is generally argued that one cannot then conclude that the “underlying processes” (i.e. series of events – J. W.) are stochastic (Connor & Simberloff 1979, 1986). However, this is not the case. If the null hypothesis has not been rejected, by adhering to the decision making procedure one can of course conclude, at this step of the analysis, that they are stochastic. One ought, however, to remember always that this conclusion must not be interpreted as evidence that stochastic factors determined the pattern observed in the field, for the following reasons.

Firstly, failure to reject the null hypothesis merely indicates that evidence of a non-random structure is not apparent in the data at hand; the hypothesis might well have been rejected with another data sample (Caswell 1976; Connor & Simberloff 1979, 1986, see also Appendix D).

Secondly, non-random or deterministic processes could have produced the patterns observed in such a way that are indistinguishable from random ones under this model (Rummel & Roughgarden 1983; Case & Sidell 1983; Rathcke 1984; Cale *et al.* 1989).

Thirdly, a random species pattern could imply that either the scale of observation was inappropriate or that no direct or indirect abiotic or biotic factors influenced this pattern. It could also be a product of noise – in this case a false rather than a true pattern would be thrown up (Smallwood 1993).

The second case (i.e. when the decision is made to reject the null hypothesis) is not usually considered, although the same objections apply. Generally speaking, if the alternative hypothesis is accepted one may conclude that the underlying processes are deterministic but, for the reasons mentioned above, this conclusion may also be unreliable.

I would like now to pay particular attention to the fact that it is often reiterated that any random pattern observed in nature might have been produced by non-random processes (see above), but nobody has said the converse, that a non-random pattern found in the field could have been generated by random processes. This intense bias in favour of deterministic processes may result from the conviction that only these processes should be studied, because only they generate community structure; stochastic processes are considered merely as noise and should therefore be eliminated from the area of investigation (see Barkman 1990). This problem, however, is not as simple as some have supposed. As was demonstrated by Yule (1927, acc. to Stone & Ezrati 1996), the apparently regular periodicity of sunspot cycles (considered for a long time to be essentially deterministic and periodic with a 10-year cycle) might in fact be nothing more than a result of random events. Generally speaking, any patterns observed in observational data might have been created by random processes. On the other hand, patterns that, at first sight, seem to be random might in reality be deterministic and may exhibit order in chaos or deterministic chaos (for details see Stone & Ezrati 1996 and references cited therein). Taking all the above into account, the following procedure for making decisions has been adopted (see also Appendix D): if the null hypothesis could be rejected it has been concluded that deterministic factors, either geographical or ecological, were responsible for the observed pattern; if not, then stochastic events were considered to have created the pattern. In this respect, my own approach corresponds to that of Fernandez-Palacios and Anderson (1993).

APPENDIX H: **Second version of the null model**

It was discovered that some subsets of the relevés examined were not representative of the statistical population with respect to the frequencies of occurrence of pleustonic species. It was found, for example, that one-species assemblages of *Lemna trisulca* did not occur in the subset of relevés made in fish-ponds and representing plant associations belonging

to the alliance *Phragmition* (FP/Ph), although, among pleustonic species, *L. trisulca* is, next to *L. minor*, the most common species in Poland (Wolek 1983). On the other hand, one-species assemblages of *Spirodela polyrhiza*, *Hydrocharis morsus-ranae* and *Salvinia natans* did appear in this subset of relevés. These pleustonic plants occur less often in Poland than *L. trisulca*. It is reasonable to assume, therefore, that the lack of one-species assemblages of *L. trisulca* is probably due to some flaws in the sampling procedures used by the original authors. Such events, not significant in certain cases, may amplify in others (e.g. in the course of combining subsets of data into one large collection) and consequently give biased results.

Facts of this kind as mentioned above, are of great importance as far as method is concerned and, therefore, any simulator program ought to include additional information about them, that is, about the structure of the sample under study. We can compare a null frequency with an observed one only when the null distribution is created under the same conditions as those that govern the observed distribution of the considered variable in a particular sample. Thus we must incorporate the rules that determine (in the context of the sample) which event can occur and which cannot. In the case of the example in question, one-species assemblages of *Lemna minor*, *Spirodela polyrhiza*, *Hydrocharis morsus-ranae* and *Salvinia natans* were found in the subset under study so their presence there is a fact. We will call facts of this kind *possible events*. As defined this term means that in the course of simulation these events may or may not happen. On the other hand, the lack of one-species assemblages of *L. trisulca* in this subset is also a fact and facts of this kind we will call *impossible events*. The implication is, that in the course of simulation according to the null model assumptions, these events cannot happen at all. It is obvious, then, that information about possible and impossible events should be incorporated into the simulator program if we wish to obtain reliable results. It is not my intention to assert that no one-species assemblages of *L. trisulca* inhabit helophytic phytocoenoses occurring in fish-ponds and belonging to associations of the alliance *Phragmition*. I only want to stress that, because of imperfect sampling procedures, one-species assemblages of this plant did not occur in the subset of relevés under study. This information, therefore, should be taken into account.

During the next stage of the investigation, the null model was supplied with additional information concerning possible and impossible events (second version of the model). So, for each species pool tested, the probability of occurrence of each pleustonic species has been estimated with respect to every category of k -species combinations (correction for non-representativeness).

APPENDIX I: The binomial distribution in ecology

It is usually the case that different localities in most natural communities appear to possess different species-carrying capacities. By contrast, the binomial distribution assumes that every locality is equally hospitable to species. Consequently, the null hypothesis that the number of species per locality has a binomial frequency distribution is seldom worth testing. This thesis was illustrated by Strauss (1982) but, as has been mentioned before

(Wolek & Pancer-Kotejowa 1988), his method of calculating the expected binomial distribution was unsound; he should have worked out the truncated expected binomial distribution for $n = 43$ species and p estimated on the basis of the observed frequency distribution of the number of fish species per locality. Instead of this, he calculated the binomial distribution for $p = 0.5$ and this value was not derived from the observed distribution as may be seen by inspection of Fig. 1 in his paper. Therefore, formally, the result obtained by Strauss (1982) should not be used as evidence supporting the thesis mentioned above.

The comparisons of the frequency distribution in question with the expected binomial distribution calculated by Strauss (1982) and with the expected truncated binomial distribution calculated by the present author are shown in Fig. 11. As can be seen from this figure, the truncated binomial distribution is a better approximation to the observed one than that calculated by Strauss but, even in this case, the difference between the distributions is still highly significant. A detailed interpretation of the result is beyond the scope of this study.

The same method of calculation of an expected binomial distribution was applied by Brown (1987). This author compared the observed frequency distribution of the different species combinations formed by 14 rodent species with the distribution of all possible different species combinations calculated for $n = 14$ and $p = 0.5$. The number of these 1,

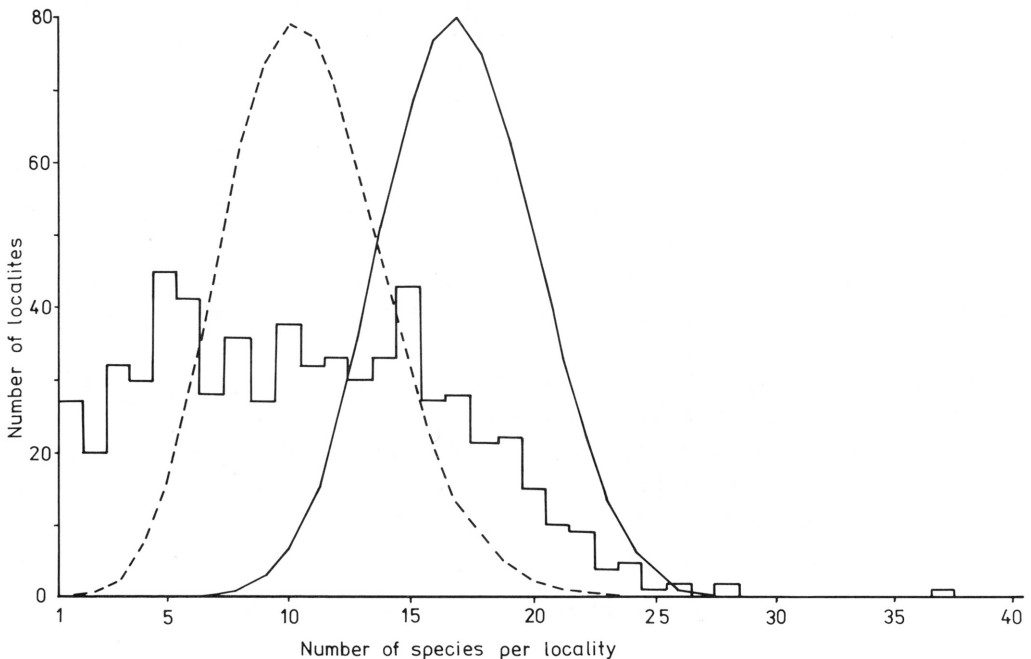

Fig. 11. Histogram of the numbers of 43 fish species, collected at each of 642 localities situated throughout the Susquehanna river drainage area in Pennsylvania (broken line), contrasted with the expected binomial distribution (solid line) calculated by Strauss (1982) and the expected truncated binomial distribution (dashed line) calculated by the present author. This binomial distribution was approximated to with the aid of the Poisson distribution, for $\lambda = 10.775$, by means of the method proposed by Wolek and Dawidowicz (1991).

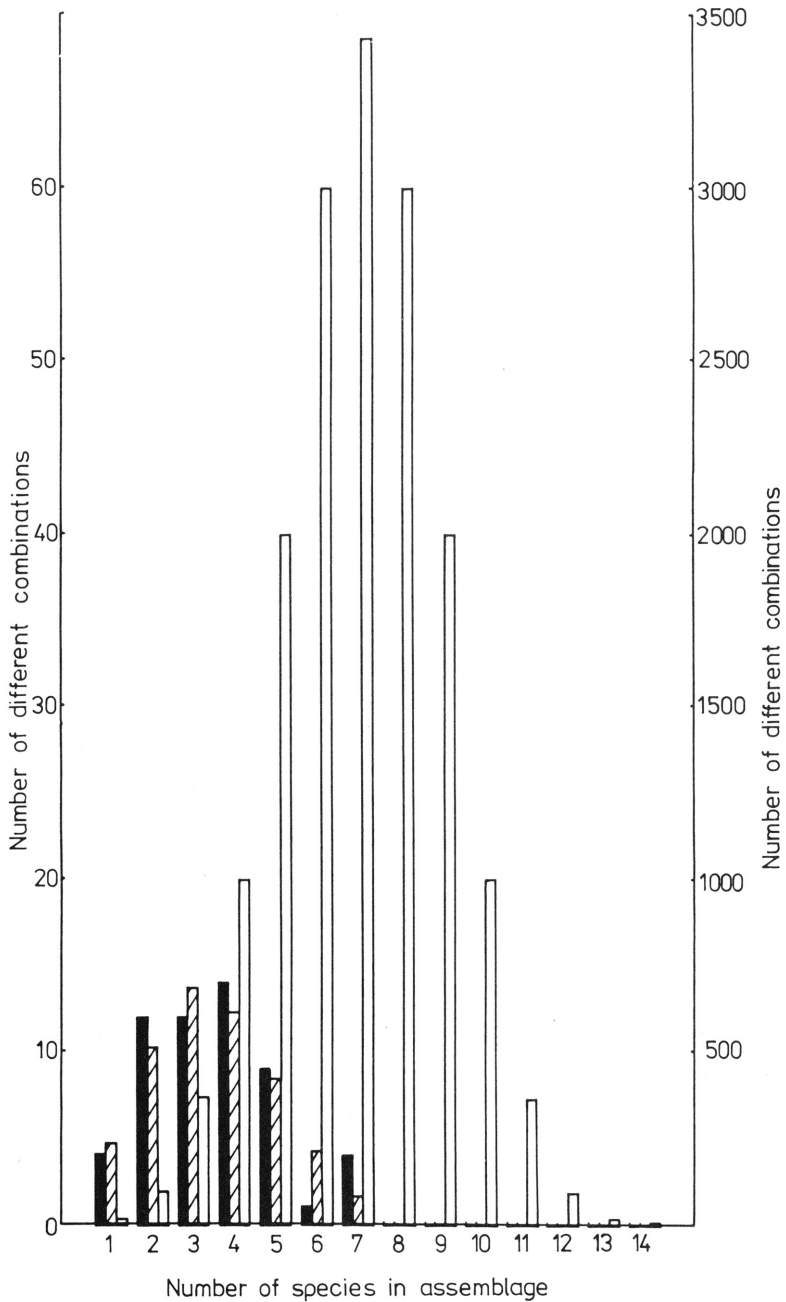

Fig. 12. Frequency distribution of 56 different observed combinations of 14 seed eating rodent species, inhabiting the arid habitats of south-western North America (black bars), contrasted with the frequency distribution of the different possible combinations of 14 species (open bars) calculated by Brown (1987) and that (shaded bars) calculated by the present author from the truncated binomial distribution, for $n = 14$ and $p = 0.25$, by means of the method proposed by Wolek and Dawidowicz (1991). The black and shaded bars relate to the scale shown on the left and the open bars to that on the right.

2, ..., 14-species combinations taken all together totals 16383, whereas in the field only 56 different species combinations were found. According to the author, this difference between the observed and expected number of species combinations suggests that local ecological interactions limit the number of coexisting rodent species and, consequently, the number of combinations formed by these species. Brown (1987) calculated all possible species combinations for the case when all 14 species have the same frequency of occurrence, i.e. $1/14$, and the probability of any species occurring at a particular site is equal to that of its occurrence at any other site, assigning to p the value 0.5. But this is not the case. As is widely known, the occurrences of species in nature are never equiprobable and, as may be seen from Fig. 9.4 in Brown (1987), the probability of success, p , is, of course, lower than 0.5. Therefore, the distribution of the different species combinations found by Brown has been compared with the expected binomial distribution calculated for $n = 14$ and $p = 0.25$. The value of p was estimated on the basis of the original observed distribution. As the zero class ($k = 0$) was missing, the truncated binomial distribution was calculated according to the method described by Wolek and Dawidowicz (1991). The results are shown in Fig. 12. The null hypothesis that there is no significant difference between the observed and truncated binomial distributions was tested by means of the chi-square test for goodness-of-fit. The results obtained ($\chi^2 = 1.224$, $df = 4$, $\chi^2_{0.05} = 9.488$) do not allow rejection of the null hypothesis. It is concluded then that the observed distribution does follow the binomial distribution, i.e. that the combinations in question, consisting of 1, 2, ..., 14 rodent species, are determined randomly and any explanation of the observed patterns in the species composition involving ecological interactions is unnecessary.

The above example shows that some evidence supporting the hypothesis that species are not randomly distributed throughout localities (i.e. do not follow the binomial distribution) may be invalid because an inappropriate method has been used for calculating the expected binomial distribution. Therefore it should be treated with caution.

Acknowledgements. An earlier draft of this paper has benefited greatly from people who have read and made helpful comments on it. In particular I would like to express my gratitude to Professor E. Pancer-Kotejowa of the Department of Forest Botany and Nature Conservation of the Agricultural University, Cracow, Professor Z. Dzwonko of the Institute of Botany at the Jagiellonian University, Cracow, and Professor K. Zarzycki of the W. Szafer Institute of Botany, Polish Academy of Sciences, Cracow. I would also like to thank an anonymous reviewer for his constructive criticism. Not all the suggestions made were implemented and I am solely responsible for any errors in the paper.

A. Sidor, M Sc, kindly made the drawings and I gratefully acknowledge her assistance.

Special thanks are due also to Mr Arthur Copping, Diss, for his meticulous work on improving the English text.

REFERENCES

- ADSRSEN H. 1988. Null hypotheses and species composition in the Galápagos Islands. – In: H. J. DURING, M. J. A. WERGER & J. H. WILLEMS (eds), *Diversity and pattern in plant communities*. pp. 37–46. SPB Academic Publishing, The Hague.
- ALATALO R. V. 1982. Bird species distributions in the Galápagos and other archipelagos: competition or chance? – *Ecology* **63**(4): 881–887.

- ALLAN J. D. 1995. Stream ecology: structure and functioning of running waters. xii + 388 pp. Chapman & Hall, London.
- ALLEN T. F. H. & HOEKSTRA T. W. 1992. Toward a unified ecology. xiv + 383 pp. Columbia University Press, New York.
- ALLEN T. F. H., KING A. W., MILNE B. T., JOHNSON A. & TURNER S. 1993. The problem of scaling in ecology. – *Evol. Trends Pl.* **7**(1): 3–8.
- ANAND M. 1994. Pattern, process and mechanism – the fundamentals of scientific inquiry applied to vegetation science. – *Coenoses* **9**(2): 81–92.
- ANGELSTAM P. 1992. Conservation of communities – the importance of edges, surroundings and landscape mosaic structure. – In: L. HANSON (ed.), *Ecological principles of nature conservation. Applications in temperate and boreal environments*, pp. 9–70. Elsevier Applied Science, London – New York.
- AUERBACH M. & SHMIDA A. 1993. Vegetation change along an altitudinal gradient on Mt Hermon, Israel – no evidence for discrete communities. – *J. Ecol.* **81**(2): 25–33.
- AUSTIN M. P. 1968. Relationships among functional properties of Californian grassland. – *Nature* **217**: 1163.
- AUSTIN M. P. 1980. Searching for a model for use in vegetation analysis. – *Vegetatio* **42**(1–3): 11–21.
- AUSTIN M. P. 1985. Continuum concept, ordination methods, and niche theory. – *Annual Rev. Ecol. Syst.* **16**: 39–61.
- AUSTIN M. P. 1986. The theoretical basis of vegetation science. – *Trends Ecol. Evol.* **1**(6): 161–164.
- AUSTIN M. P. 1990. Community theory and competition in vegetation. – In: J. B. GRACE & D. TILMAN (eds), *Perspectives on plant competition*, pp. 215–238. Academic Press, San Diego.
- AUSTIN M. P. & SMITH T. M. 1989. A new model for continuum concept. – *Vegetatio* **83**(1–2): 35–47.
- BARKMAN J. J. 1979. The investigation of vegetation texture and structure. – In: M. J. A. WERGER (ed.), *The study of vegetation*, pp. 125–160. W. Junk, The Hague.
- BARKMAN J. J. 1990. Controversies and perspectives in plant ecology and vegetation science. – *Phytocoenologia* **18**(4): 565–589.
- BARNET V. 1982. Elementy teorii pobierania prób [Elements of sampling theory]. 212 pp. Państwowe Wydawnictwo Naukowe, Warszawa (in Polish translated from English).
- BORNKAMM R. 1963. Erscheinung der Konkurrenz zwischen höheren Pflanzen und ihre begriffliche Fassung. – *Ber. Geobot. Inst. ETH, Stiftung Rübel* **34**: 83–107.
- BOUXIN G. & GAUTIER N. 1982. Pattern analysis in Belgian limestone grasslands. – *Vegetatio* **49**(2): 65–83.
- BRAUN-BLANQUET J. 1921. Prinzipien einer Systematik der Pflanzengesellschaften auf floristischer Grundlage. – *Jahrb. St. Gallischen Naturwiss. Ges.* **57**(2): 305–351.
- BRAUN-BLANQUET J. 1932. Plant sociology. The study of plant communities. xviii + 439 pp. McGraw-Hill, New York – London.
- BROWN J. H. 1987. Variation in desert rodent guilds: patterns, processes, and scales. – In: J. H. R. GEE & P. S. GILLER (eds), *Organization of communities*, pp. 185–203. Blackwell, Oxford.
- CALE W. G., HENEERY G. H. & YEAKLY J. A. 1989. Inferring process from pattern in natural communities. – *BioScience* **39**(9): 600–605.
- CARPENTER J. R. 1950. An ecological glossary. 306 pp. Hafner, New York.
- CASE T. J. & SIDELL R. 1983. Pattern and chance in the structure of model and natural communities. – *Evolution* **37**: 832–849.
- CASWELL H. 1976. Community structure: a neutral model analysis. – *Ecol. Monogr.* **46**(3): 327–354.

- CHAPLEAU F., JOHANSEN P. H. & WILLIAMSON M. 1988. The distinction between pattern and process in evolutionary biology: the use and abuse of the term "strategy". – *Oikos* **53**(1): 136–138.
- CHESSON P. L. & CASE T. J. 1986. Nonequilibrium community theories: chance, variability, history, and coexistence. – In: J. DIAMOND & T. J. CASE (eds), *Community ecology*, pp. 229–239. Harper & Row, New York.
- CHRISTIANSEN F. B. & FENCHEL T. M. 1977. *Theories of populations in biological communities*. Springer, New York.
- CLATWORTHY J. N. & HARPER J. L. 1962. The comparative biology of closely related species living in the same area. V. Inter- and intraspecific interference within cultures of *Lemna* spp. and *Salvinia natans*. – *J. Exp. Bot.* **13**: 307–324.
- CLEMENTS F. E. 1916. *Plant succession. An analysis of the development of vegetation*. xiii + 512 pp. Carnegie Institution of Washington, Washington.
- CLEMENTS F. E. 1928. *Plant succession and indicators*. xvi + 453 pp. Hafner, New York – London.
- CLEMENTS F. E. 1936. Nature and structure of the climax. – *J. Ecol.* **24**(1): 552–584.
- CODY M. L. 1989. Discussion: structure and assembly of communities. – In: J. ROUGHGARDEN, R. M. MAY & S. A. LEVIN (eds), *Perspectives in ecological theory*. pp. 227–241. Princeton University Press, Princeton.
- COLE L. C. 1951. Population cycles and random oscillations. – *J. Wildlife Managem.* **15**: 233–252.
- COLE B. J. 1991. Reply to D. Gordon. – *Amer. Naturalist* **137**: 262–263.
- COLLIER B. D., COX G. W., JOHNSON A. W. & MILLER Ph. C. 1973. *Dynamic ecology*. 563 pp. Prentice-Hall, Englewood Cliffs.
- COLLINS S. L., GLENN S. M. & ROBERTS D. W. 1993. The hierarchical continuum concept. – *J. Veg. Sci.* **4**(2): 149–156.
- COLWELL R. K. & WINKLER D. W. 1984. A null model for null models in biogeography. – In: D. R. STRONG, Jr., D. SIMBERLOFF, L. G. ABELE & A. B. THISTLE (eds), *Ecological communities: conceptual issues and the evidence*, pp. 344–359. Princeton University Press, Princeton.
- CONNELL J. H. 1983. On the prevalence and relative importance of interspecific competition: evidence from field experiments. – *Amer. Naturalist* **122**(5): 661–696.
- CONNELL J. H. 1990. Apparent versus "real" competition in plants. – In: J. B. GRACE & D. TILMAN (eds), *Perspectives on plant competition*, pp. 9–26. Academic Press, San Diego.
- CONNOR E. F. & SIMBERLOFF D. 1978. Species number and compositional similarity of the Galápagos flora and avifauna. – *Ecol. Monogr.* **48**(2): 219–248.
- CONNOR E. F. & SIMBERLOFF D. 1979. The assembly of species communities: chance or competition? – *Ecology* **60**(6): 1132–1140.
- CONNOR E. F. & SIMBERLOFF D. 1983. Interspecific competition and species co-occurrence patterns on islands: null models and the evaluation of evidence. – *Oikos* **41**(2): 455–465.
- CONNOR E. F. & SIMBERLOFF D. 1984. Neutral models of species co-occurrence patterns. – In: D. R. STRONG, Jr., D. SIMBERLOFF, L. G. ABELE & A. B. THISTLE (eds), *Ecological communities: conceptual issues and the evidence*, pp. 316–331. Princeton University Press, Princeton.
- CONNOR E. F. & SIMBERLOFF D. 1986. Competition, scientific method and null models in ecology. – *Amer. Sci.* **74**: 155–162.
- CONOVER W. J. 1971. *Practical nonparametric statistics*. xii + 462 pp. John Wiley & Sons Inc., New York – London – Sydney – Toronto.
- CRAWLEY M. J. 1983. *Herbivory. The dynamics of animal-plant interactions*. – In: *Studies in ecology*. **10**. x + 437 pp. University California Press, Berkeley – Los Angeles.

- CRAWLEY M. J. 1989a. The structure of plant communities. – In: M. J. CRAWLEY (ed.), *Plant ecology*, pp. 1–50. Blackwell, Oxford.
- CRAWLEY M. J. 1989b. Chance and timing in biological invasions. – In: J. A. DRAKE, H. A. MOONEY, F. DI CASTRO, R. H. GROVES, F. J. KRUGER, M. REJMÁNEK & M. WILLIAMSON (eds), *Biological invasions: a global perspective*, pp. 407–423. J. Wiley & Sons, Chichester – New York – Brisbane – Toronto.
- CURTIS J. T. & MCINTOSH R. P. 1950. The interrelation of certain analytic and synthetic phytosociological characters. – *Ecology* **31** (3): 434–455.
- DALE M. B. 1994. Do ecological communities exist? – *J. Veg. Sci.* **5**(2): 285–286.
- DAUBENMIRE R. F. 1966. Vegetation: identification of typl communities. – *Science* **151**: 291–298.
- DAYTON P. K. & TEGUER M. J. 1984. The importance of scale in community ecology: a kelp forest example with terrestrial analogues. – In: P. W. PRICE, C. N. SLOBODCHIKOFF & W. S. GAUDE (eds), *A new ecology: novel approaches to interactive systems*, pp. 457–481. J. Wiley & Sons, New York.
- DEANGELIS D. L. & WATERHOUSE J. C. 1987. Equilibrium and nonequilibrium concepts in ecological models. – *Ecol. Monogr.* **57**(1): 1–21.
- DE LANGE L. 1972. An ecological study of ditch vegetation in the Netherlands. 112 pp. Mscr. of Ph. D. thesis, University of Amsterdam, Amsterdam.
- DE LANGE L. 1975. Gibbosity in the complex *Lemna gibba/Lemna minor*: Literature survey and ecological aspects. – *Aquatic Bot.* **1**: 327–332.
- DE LANGE L. & PIETERSE A. H. 1973. A comparative study of the morphology of *Lemna gibba* L. and *Lemna minor* L. – *Acta Bot. Neerl.* **22**: 510–517.
- DE LANGE L. & WESTINGA E. 1979. The distinction between *Lemna gibba* and *Lemna minor* on the basis of vegetative characters. – *Acta Bot. Neerl.* **28**: 169–176.
- DEN HARTOG C. 1978. Subjective phytosociology of aquatic plants. – *Aquatic Bot.* **4**: 96–98.
- DEN HARTOG C. & SEGAL S. 1964. A new classification of the water-plant communities. – *Acta Bot. Neerl.* **13**(3): 367–393.
- DEN HARTOG C. & VAN DER VELDE G. 1988. Structural aspect of aquatic plant communities. – In: J. J. SYMOENS (ed.), *Vegetation of inland waters*, pp. 113–153. Kluwer, Dordrecht – Boston – London.
- DIAMOND J. M. 1975. Assembly of species communities. – In: M. L. Cody & J. M. Diamond (eds), *Ecology and evolution of communities*, pp. 342–444. Harvard University Press, Cambridge, USA.
- DIAMOND J. M. & GILPIN M. E. 1982. Examination of the “null” model of Connor & Simberloff for species co-occurrences on islands. – *Oecologia* **52**: 64–74.
- DRAKE J. A. 1990. Communities as assembled structures: do rules govern pattern. – *Trends Ecol. Evol.* **5**(5): 159–164.
- DRAKE J. A. 1991. Community-assembly mechanics and the structure of an experimental species assembly. – *Amer. Naturalist* **137**: 1–26.
- DZWONKO Z. & GRODZIŃSKA K. 1979. Numerical classification of epilithic and xerothermic communities in the Pieniny Mountains (Western Carpathians). – *Fragm. Flor. Geobot.* **25**(4): 493–508.
- EDSON M. M., FOIN T. C. & KNAPP C. M. 1981. “Emergent properties” and ecological research. – *Amer. Naturalist* **118**: 593–596.
- ERNST W. 1978. Discrepancy between ecological and physiological optima of plant species. A re-interpretation. – *Oecol. Pl.* **13**(2): 175–188.
- FERNÁNDEZ-PALACIOS J. M. & ANDERSON C. 1993. Species composition and within archipelago co-occurrence patterns in the Canary Islands. – *Ecography* **16**: 31–36.
- FERRIERE R. & FOX G. A. 1995. Chaos and evolution. *Trends Ecol. Evol.* **10**(12): 480–485.

- FITTER A. H. 1987. Spatial and temporal separation of activity in plant communities: prerequisite or consequence of coexistence? – In: J. H. R. GEE & P. S. GILLER (eds), *Organization of communities. Past and present*, pp. 119–139. Blackwell, Oxford.
- FOX B. J. 1987. Species assembly and evolution of community structure. – *Evol. Ecol.* 1: 201–213.
- FOX B. J. & BROWN J. H. 1993. Assembly rules for functional groups in North American desert rodent communities. – *Oikos* 67(2): 358–370.
- FOX B. J. & BROWN J. H. 1995. Reaffirming the validity of the assembly rule for functional groups or guilds: a reply to Wilson. – *Oikos* 73(1): 125–132.
- GILLER P. S. & GEE J. H. R. 1987. The analysis of community organization: the influence of equilibrium, scale and terminology. – In: J. H. R. GEE & P. S. GILLER (eds), *Organization of communities. Past and present*, pp. 519–542. Blackwell, Oxford.
- GILPIN M. E. & DIAMOND J. M. 1982. Factors contributing to non-randomness in species co-occurrences on islands. – *Oecologia* 52: 75–84.
- GILPIN M. E. & DIAMOND J. M. 1984. Are species co-occurrences on islands non-random, and are null hypotheses useful in community ecology? – In: D. R. STRONG, Jr., D. SIMBERLOFF, L. G. ABELE & A. B. THISTLE (eds), *Ecological communities: conceptual issues and the evidence*, pp. 297–315. Princeton University Press, Princeton.
- GILPIN M. E. & DIAMOND J. M. 1987. Comments on Wilson's null model. – *Oecologia* 74: 159–160.
- GLAVAC V., GRILLENBERG C., HAKES W. & ZIEZOLD H. 1992. On the nature of vegetation boundaries, undisturbed flood plain forest communities as an example – a contribution to the continuum/discontinuum controversy. – *Vegetatio* 101(2): 123–144.
- GLEASON H. A. 1917. The structure and development of the plant association. – *Bull. Torrey Bot. Club* 44: 463–481.
- GLEASON H. A. 1926. The individualistic concept of the plant association. – *Bull. Torrey Bot. Club* 53: 7–26.
- GLEASON H. A. 1939. The individualistic concept of the plant association. – *Amer. Midl. Naturalist* 21: 92–110.
- GOODALL D. W. 1954. Vegetational classification and vegetational continua. – *Angew. Pflanzensoziol.* 1: 168–182.
- GOODALL D. W. 1963. The continuum and individualistic association. – *Vegetatio* 11(5–6): 297–316.
- GORDON D. M. 1991. Comment on an article by B. Cole. – *Amer. Naturalist* 137: 260–261.
- GRACE J. B. & TILMAN D. (eds) 1990. *Perspectives on plant competition*. xiv + 484 pp. Academic Press, San Diego.
- GRANT P. R. & ABBOTT I. A. 1980. Interspecific competition, island biogeography, and null hypotheses. – *Evolution* 34: 332–341.
- GREIG-SMITH P. 1979. Pattern in vegetation. – *J. Ecol.* 67(3): 755–779.
- GRIME J. P. 1979. *Plant strategies and vegetation processes*. xi + 222 pp. John Wiley, Chichester – New York – Brisbane – Toronto.
- GRUBB P. J. 1977. The maintenance of species – richness in plant communities: the importance of the regeneration niche. – *Biol. Rev.* 52: 107–145.
- GRUBB P. J. 1987. Global trends in species – richness in terrestrial vegetation: a view from the Northern Hemisphere. – In: J. H. R. GEE & P. S. GILLER (eds), *Organization of communities. Past and present*, pp. 99–118. Blackwell, Oxford.
- HAILA Y. 1983. *Ecology of island colonization by northern land birds: a quantitative approach* [“An introduction to the collection of eight papers presented as a doctoral thesis”]. 10 pp. Helsingin yliopiston monistuspalvelu Painatusjaos, Helsinki.

- HARPER J. L. 1977. Population biology of plants. Academic Press, New York.
- HARVEY P. H., COLWELL R. K., SILVERTON J. W. & MAY R. M. 1983. Null models in ecology. – Annual Rev. Ecol. Syst. **14**: 189–211.
- HICKS L. E. 1932. Ranges of pH tolerance of Lemnaceae. – Ohio J. Sci. **32**: 237–244.
- HOGEWEG P., HESPER B., VAN SCHAİK C. P. & BEEFTINK W. G. 1985. Patterns in vegetation succession, an ecomorphological study. – In: J. WHITE (ed.), The population structure of vegetation, pp. 637–666. W. Junk, Dordrecht.
- HORNE J. K. & SCHNEIDER D. C. 1994. Analysis of scale-dependent processes with dimensionless ratios. – Oikos **70**(2): 201–211.
- HUNTLEY N. 1991. Herbivores and the dynamics of communities and ecosystems. – Annual Rev. Ecol. Syst. **22**: 477–503.
- HUTCHINSON G. E. 1953. The concept of pattern in ecology. – Proc. Acad. Nat. Sci. Philadelphia **105**: 1–12.
- IVERSEN J. 1929. Studien über die pH-Verhältnisse dänischer Gewässer und ihren Einfluss auf die Hydrophyten-Vegetation. – Bot. Tidsskr. **40**: 277–333.
- JACKSON D. A., SOMERS K. M. & HARVEY H. H. 1992. Null models and fish communities: evidence of nonrandom patterns. – Amer. Naturalist **139**(5): 930–951.
- JÄRVINEN O. 1982. Species-to-genus ratios in biogeography: a historical note. – J. Biogeogr. **9**: 363–370.
- JENSEN S. & VAN DER MAAREL E. 1980. Numerical approaches to lake classification with special reference to macrophyte communities. – Vegetatio **42**(1–3): 117–128.
- JONCKERS L. H. M. 1973. The concept of population in biology. – Acta Biotheor. **22**(2): 78–108.
- KANDELER R. 1975. Species delimitation in the genus *Lemna*. – Aquatic Bot. **1**: 365–376.
- KEDDY P. A. 1976. Lakes as islands: the distributional ecology of two aquatic plants, *Lemna minor* L. and *L. trisulca* L. – Ecology **57**(2): 353–359.
- KEDDY P. A. 1989. Competition. xi + 202 pp. Chapman & Hall, London – New York.
- KEDDY P. A. 1990. The use of functional as opposed to phylogenetic systematics: a first step in predictive community ecology. – In: S. KAWANO (ed.), Biological approaches and evolutionary trends in plants, pp. 387–406. Academic Press, London.
- KEDDY P. A. 1992. Assembly and response rules: two goals for predictive community ecology. – J. Veg. Sci. **3**(2): 157–164.
- KEDDY P. A. 1993. Do ecological communities exist? A reply to Bastow Wilson. – J. Veg. Sci. **4**(1): 135–136.
- KENDALL M. G. & BUCKLAND W. R. 1960: A dictionary of statistical terms. xii + 575 pp. Oliver & Boyd, Edinburgh – London.
- KERSHAW K. A. & LOONEY J. H. H. 1985. Quantitative and dynamic plant ecology. Ed. 3. iv + 282 pp. Edward Arnold, London.
- KĘPCZYŃSKI K. 1960: Zespoły roślinne jezior Skępskich i otaczających je łąk [Plant groups of the lake district of Skępe and the surrounding peat-bogs]. – Stud. Soc. Sci. Torun. Suppl. **6**: 1–244 (in Polish with English summary).
- KĘPCZYŃSKI K. 1965. Szata roślinna Wysoczyzny Dobrzyńskiej [Die Pflanzenwelt des Diluvialplateau's von Dobrzyń]. 321 pp. Wydawnictwo Uniw. M. Kopernika, Toruń (in Polish with German summary).
- KĘPCZYŃSKI K. & FABISZAK S. 1972. *Salvinia natans* (L.) All. i zespół *Spirodello-Salvinietum* Sławnic 1956 na terenie województwa bydgoskiego [*Salvinia natans* (L.) All. und *Spirodello-Salvinietum* Sławnic 1956 in der Woiwodschaft Bydgoszcz]. – Zesz. Nauk. Uniw. Mikołaja Kopernika w Toruniu, Nauki Mat.-Przyr. 30 Biologia **15**: 33–40 (in Polish with German summary).

- KITAYAMA K. K. & MUELLER-DOMBOIS D. 1995. Biological invasion on an oceanic island mountain: do alien plant species have wider ecological ranges than native species? – *J. Veg. Sci.* **6**(5): 667–674
- KLÖTZLI F. 1995. Projected and chaotic changes in forest and grassland plant communities. Preliminary notes and theses. – *Ann. Bot.* **53**: 225–231.
- KORDAKOW J. 1970. Nowe stanowiska *Limnanthemum nymphoides* (L.) Link, *Salvinia natans* (L.) All., *Lemna gibba* L. i *Wolffia arrhiza* (L.) Wimm. nad dolną Wisłą [New localities of *Limnanthemum nymphoides* (L.) Link, *Salvinia natans* (L.) All., *Lemna gibba* L. and *Wolffia arrhiza* (L.) Wimm. along the lower Vistula]. – *Bad. Fizjogr. Pol. Zach. Ser. B – Botanika* **23**: 243–250 (in Polish with English summary).
- KRZYWAŃSKA J. & KRZYWAŃSKI D. 1972. Zarastanie dołów potorfowych i rowów melioracyjnych w dolinie Warty pod Małkowem i Bartochowem. Cz. 1. Zbiorowiska roślin wodnych pleustonowych i zakorzenionych oraz zbiorowiska oczerzetów [The development of vegetation in peat pits and meliorative ditches in the valley of Warta-river near Małków and Bartochów. Part 1. Aquatic communities of pleustonic and rooted plants as well as rush communities]. – *Zesz. Nauk. Uniw. Łódz. Ser. 2*, **51**: 127–144 (in Polish with English summary).
- LANDOLT E. 1957. Physiologische und ökologische Untersuchungen an Lemnaceen. – *Ber. Schweiz. Bot. Ges.* **67**: 271–410.
- LANDOLT E. 1975. Morphological differentiation and geographical distribution of the *Lemna gibba-Lemna minor* group. – *Aquatic Bot.* **1**: 345–363.
- LANDOLT E. 1981. Distribution pattern of the family Lemnaceae in North Carolina. – *Veröff. Geobot. Inst. ETH Stiftung Rübel Zürich* **77**: 112–148.
- LANDOLT E. 1982. Distribution pattern and ecophysiological characteristics of the European species of the Lemnaceae. – *Ber. Geobot. Inst. ETH Stiftung Rübel Zürich* **49**: 127–145.
- LANDOLT E. 1984. Verbreitungsmuster in der Familie der Lemnaceae und ihre ökologische Deutung. – *Verh. Ges. Oekol. (Bern 1982)* **12**: 241–253.
- LANDOLT E. 1986. The family of Lemnaceae – a monographic study. **1**. – *Veröff. Geobot. Inst. ETH Stiftung Rübel Zürich* **71**: 1–566.
- LANDOLT E. & KANDELER R. 1987. The family of Lemnaceae – a monographic study. **2**. – *Veröff. Geobot. Inst. ETH Stiftung Rübel Zürich* **95**: 1–638.
- LANDOLT E. & WILDI O. 1977. Oekologische Felduntersuchungen bei Wasserlinsen (Lemnaceae) in den südwestlichen Staaten der USA. – *Ber. Geobot. Inst. ETH Stiftung Rübel Zürich* **44**: 104–146.
- LANDOLT E. & ZARZYCKI K. 1994. Ecological field investigations of duckweed (Lemnaceae) in Argentina. – *Ber. Geobot. Inst. ETH Stiftung Rübel Zürich* **60**: 62–109.
- LAW R. & WATKINSON A. R. 1989. Competition. – In: J. M. CHERRETT (ed.), *Ecological concepts: the contribution of ecology to an understanding of the natural world*, pp. 243–284. Blackwell, Oxford.
- LAWTON J. H. 1987. Are there assembly rules for successional communities? – In: A. J. GRAY, M. J. CRAWLEY & P. J. EDWARDS (eds), *Colonization, succession and stability*, pp. 225–244. Blackwell, Oxford.
- LEVIN S. A. 1992. The problem of pattern and scale in ecology. – *Ecology* **73**(6): 1943–1967.
- LOEHLE C. 1988. Philosophical tools: potential contributions to ecology. – *Oikos* **51**(1): 97–104.
- LORENZ E. N. 1963. Deterministic nonperiodic flow. – *J. Atm. Sci.* **20**: 130–141.
- MACARTHUR R. 1971. Patterns of terrestrial bird communities. – In: D. S. FARNER, J. R. KING & K. C. PARKES (eds), *Avian biology*, **1**, pp. 189–221. Academic Press, New York.
- MACARTHUR R. H. & WILSON E. O. 1967. *The theory of island biogeography*. 203 pp. Princeton University Press, Princeton.
- MAGURRAN A. E. 1988. *Ecological diversity and its measurement*. x + 179 pp. Croom Helm, London – Sydney.

- MASON H. L. 1947. Evolution of certain floristic associations in Western North America. – *Ecol. Monogr.* **17**: 203–210.
- MASON H. L. & LANGENHEIM J. H. 1957. Language analysis and the concept *environment*. – *Ecology* **38**(2): 325–340.
- MATUSZKIEWICZ W. 1947. Zespoły leśne południowego Polesia [The forest associations of South-Polesia]. – *Ann. Univ. M. Curie-Skłodowska Sect. E* **2**(5): 69–138 (in Polish with English summary).
- MATUSZKIEWICZ W. 1948. Roślinność lasów okolic Lwowa [The vegetation of the forests of the environs of Lvov]. – *Ann. Univ. M. Curie-Skłodowska Sect. C* **3**(5): 119–193 (in Polish with English summary).
- MATUSZKIEWICZ W., 1981: Przewodnik do oznaczania zbiorowisk roślinnych Polski [“Guide to determination of plant communities in Poland”]. 298 pp. Państwowe Wydawnictwo Naukowe, Warszawa (in Polish).
- MAY R. M. 1984. An overview: real and apparent patterns in community structure. – In: D. R. STRONG, Jr., D. SIMBERLOFF, L. G. ABELE & A. B. THISTLE (eds), *Ecological communities: conceptual issues and the evidence*, pp. 3–16. Princeton University Press, Princeton.
- MCINTOSH R. P. 1967a. The continuum concept of vegetation. – *Bot. Rev.* **33**: 130–187.
- MCINTOSH R. P. 1967b. An index of diversity and the relation of certain concepts to diversity. – *Ecology* **48**(3): 392–404.
- MCINTOSH R. P. 1975. Gleason – “individualistic ecologist”, 1882–1975: his contributions to ecological theory. – *Bull. Torrey Bot. Club* **102**(5): 253–273.
- MCINTOSH R. P. 1993. The continuum continued: John T. Curtis’ influence on ecology. – In: J. S. FRALISH, R. P. MCINTOSH, O. L. LOUCKS (eds), *John T. Curtis: fifty years of Wisconsin plant ecology*. pp. 95–122. Wisconsin Academy of Science, Arts and Letters, Madison.
- MCLAY L. C. 1974. The distribution of duckweed *Lemna perpusilla* in a small southern California lake: an experimental approach. – *Ecology* **55**(2): 262–276.
- MILNE A. 1961. Definition of competition among animals. – *Symposia of the Society for Experimental Biology* **15**: 40–61.
- MINCHIN P. R. 1989. Montane vegetation of the Mt. Field massif, Tasmania: a test of some hypotheses about properties of community patterns. – *Vegetatio* **83**(1–2): 97–110.
- MIRKIN B. M. 1987. Paradigm change and vegetation classification in soviet phytosociology. – *Vegetatio* **68**(3): 131–138.
- MIRKIN B. M. 1994. Which plant communities do exist? – *J. Veg. Sci.* **5**(2): 283–284.
- MIYAWAKI A. & TÜXEN J. 1960. Über Lemnetae-Gesellschaften in Europa und Japan. – *Mitt. Florist.-Soziol. Arbeitsgem.* **8**: 127–135.
- MOORE J. J. 1962. The Braun-Blanquet system. A reassessment. – *J. Ecol.* **50**(3): 761–769.
- MORAVEC J. 1989. Influences of the individualistic concept of vegetation on syntaxonomy. – *Vegetatio* **81**(1–2): 29–39.
- MOULTON M. P. & PIMM S. L. 1986. The extent of competition in shaping an introduced avifauna. – In: J. DIAMOND & T. J. CASE (eds), *Community ecology*, pp. 80–97. Harper & Row, New York.
- MOYLE J. B. 1945. Some chemical factors influencing the distribution of aquatic plants in Minnesota. – *Amer. Midl. Naturalist* **34**: 402–420.
- MUELLER-DOMBOIS D. & ELLENBERG H. 1974. *Aims of vegetation ecology*. xx + 547 pp. John Wiley & Sons, New York – London – Sydney – Toronto.
- MÜLLER TH. & GÖRS S. 1960. Pflanzengesellschaften stehender Gewässer in Baden-Württemberg. – *Beitr. Naturk. Forsch. Südwestdeutschl.* **19**: 60–100.
- NORCLIFF G. B. 1986. Statystyka dla geografów. Wprowadzenie [Inferential statistics for geographers.

- An introduction]. 258 pp. Państwowe Wydawnictwo Naukowe, Warszawa (in Polish translated from English).
- NOY-MEIR I. & VAN DER MAAREL E. 1987. Relations between community theory and community analysis in vegetation science: some historical perspectives. – *Vegetatio* **69**(1–3): 5–15.
- OBERDORFER E. 1957. Süddeutsche Pflanzengesellschaften. – In: *Pflanzensociologie*. **10**. xxvii + 567 pp. G. Fischer, Jena.
- OCHYRA R. & TOMASZEWICZ H. 1979. Nowe stanowiska *Ricciocarpos natans* (L.) Corda (Ricciaceae, Hepaticopsida) i przegląd jego rozmieszczenia w Polsce [New localities of *Ricciocarpos natans* (L.) Corda (Ricciaceae, Hepaticopsida) and review of its distribution in Poland]. – *Fragm. Flor. Geobot.* **25**(3): 429–438 (in Polish with English summary).
- O'CONNOR R. J. 1987. Organization of avian assemblages – the influence of intraspecific habitat dynamics. – In: J. H. R. GEE & P. S. GILLER (eds), *Organization of communities. Past and present*, pp. 163–184. Blackwell, Oxford.
- ODUM E. P. 1963. *Podstawy ekologii* [Fundamentals of ecology]. xvi + 560 pp. Państwowe Wydawnictwo Rolnicze i Leśne, Warszawa (in Polish translated from English).
- ODUM E. P. 1986. Introductory review: perspective of ecosystem theory and application. – In: N. Poulunin (ed.), *Ecosystem theory and application*, pp. 1–11. J. Wiley & Sons, Chichester.
- OKUBO A. 1980. *Diffusion and ecological problems: mathematical models*. xiii + 254 pp. Springer, Berlin – Heidelberg – New York.
- OLACZEK R. & KRZYWAŃSKI D. 1970. *Wolffia arrhiza* i *Wolffietum arrhizae* w Polsce [*Wolffia arrhiza* and *Wolffietum arrhizae* in Poland]. – *Zesz. Nauk. Uniw. Łdz. Nauki Mat.-Przyr.* Ser. 2, **36**: 39–51 (in Polish with English summary).
- PALMER M. W. 1994. Variation in species richness: towards a unification of hypotheses. – *Folia Geobot. Phytotax.* **29**(4): 511–530.
- PALMER M. W. & VAN DER MAAREL E. 1995. Variance in species richness, species association, and niche limitation. – *Oikos* **73**(2): 203–213.
- PALMER M. W. & WHITE P. S. 1994. On the existence of ecological communities. – *J. Veg. Sci.* **5**(2): 279–282.
- PASSARGE H. 1978. Zur Syntaxonomie mitteleuropäischer *Lemnetea*-Gesellschaften. – *Folia Geobot. Phytotax.* **13**(1): 1–16.
- PÄRTEL M., ZOBEL M., ZOBEL K. & VAN DER MAAREL E. 1996. The species pool and its relation to species richness: evidence from Estonian plant communities. – *Oikos* **75**(1): 111–117.
- PEARSAL W. H. 1920. The aquatic vegetation of the English lakes. – *J. Ecol.* **8**: 163–201.
- PECHENYUK H. 1984. *Lemna gibba* (Lemnaceae) v Khoperskom gosudarstvennom zapovednike [*Lemna gibba* (Lemnaceae) in the Khopersk State Reserve]. – *Bot. Zhurn.* **69**(8): 1101–1102. (in Russian with English summary).
- PEET R. K. 1974. The measurement of species diversity. – *Annual Rev. Ecol. Syst.* **5**: 285–307.
- PETERS R. H. 1991. *A critique for ecology*. xiv + 366 pp. University Press, Cambridge.
- PIANKA E. R. 1981. *Ekologia ewolucyjna* [Evolutionary ecology]. 342 pp. Państwowe Wydawnictwo Naukowe, Warszawa (in Polish translated from English).
- PICKETT S. T. A. 1980. Non-equilibrium coexistence of plants. – *Bull. Torrey Bot. Club* **107**(2): 238–248.
- PIETERSE A. H. 1975. Physiological, morphological and anatomical aspects of gibbosity in *Lemna gibba*. – *Aquatic Bot.* **1**: 333–344.
- PIÓRECKI J. 1975. *Trapa natans* L. w Kotlinie Sandomierskiej (ekologia, rozmieszczenie i ochrona)

- [*Trapa natans* L. in the Sandomierz Basin (ecology, distribution and protection)]. – Roczn. Przemyski **15–16**: 347–400 (in Polish with English summary).
- PODBIELKOWSKI Z. 1960. Zarastanie dołów potorfowych [The development of vegetation in peat pits]. – Monogr. Bot. **10**: 1–144 (in Polish with English summary).
- PODBIELKOWSKI Z. 1967. Zarastanie rowów melioracyjnych na torfowiskach okolic Warszawy [Entwicklung der Vegetation in den Meliorationsgräben]. – Monogr. Bot. **23**: 1–171 (in Polish with German summary).
- PODBIELKOWSKI Z. 1968. Roślinność stawów rybnych województwa warszawskiego [Die Vegetation der Fischteiche der Woiwodschaft Warszawa]. – Monogr. Bot. **27**: 1–123 (in Polish with German summary).
- PODBIELKOWSKI Z. 1969. Roślinność glinianek województwa warszawskiego [Vegetation der Lehmgruben der Woiwodschaft Warszawa]. – Monogr. Bot. **30**: 119–156. (in Polish with German summary).
- PODBIELKOWSKI Z. & TOMASZEWICZ H. 1974. Syntaxonomic position of *Hydrocharitetum morsuranae* van Langendonck 1935. – Acta Soc. Bot. Pol. **43**(3): 377–380.
- POLAKOWSKI B. & DZIEDZIC J. 1972. Zespół *Hydrocharitetu morsuranae* van Langendonck 1935 w północno-wschodniej Polsce [Das *Hydrocharitetum morsuranae* van Langendonck 1935 in Nordostpolen]. – Fragm. Flor. Geobot. **18**(3–4): 353–358 (in Polish with German summary).
- PONYATOVSKAYA V. M. 1961. On two trends in phytosociology. – Vegetatio **10**(5–6): 373–379.
- POORE M. E. D. 1955a. The use of phytosociological methods in ecological investigations. I. The Braun-Blanquet system. – J. Ecol. **43**(1): 226–244.
- POORE M. E. D. 1955b. The use of phytosociological methods in ecological investigations. II. Practical issues involved in an attempt to apply the Braun-Blanquet system. – J. Ecol. **43**(1): 245–269.
- POORE M. E. D. 1955c. The use of phytosociological methods in ecological investigations. III. Practical applications. – J. Ecol. **43**(2): 606–651.
- POORE M. E. D. 1956. The use of phytosociological methods in ecological investigations. IV. General discussion of phytosociological problems. – J. Ecol. **44**(1): 28–50.
- POTT R. 1981. Oekologie und Indikatorwert von Wasserpflanzengesellschaften. – Mitt. Landesanst. Oekologie, Landschaftsentw., Forstplanung Nordrhein-Westf., Sonderheft Landestagungen **1980**: 57–64.
- PRICE P. W. 1984. Alternative paradigms in community ecology. – In: P. W. PRICE, C. N. SLOBODCHIKOFF & W. S. GOULD (eds), A new ecology: novel approaches to interactive systems, pp. 354–381. J. Wiley & Sons, New York – Chichester – Brisbane.
- PRICE P. W., SLOBODCHIKOFF C. N. & GOULD W. S. (eds) 1984. A new ecology: novel approaches to interactive systems. x + 481 pp. John Wiley & Sons, New York – Chichester – Brisbane.
- QUINN J. F. & DUNHAM A. E. 1983. On hypothesis testing in ecology and evolution. – Amer. Naturalist **122**(5): 602–617.
- RAMENSKY L. G. 1924. Die Grundgesetzmäßigkeiten in Aufbau der Vegetationsdecke. – Bot. Centralbl., N. F., **7**: 453–455.
- RAVERA O. 1984. Considerations on some ecological principles. – In: J. H. COOLEY & F. B. GOLLEY (eds), Trends in ecological research for the 1980s, pp. 145–162. Plenum Press, New York – London.
- RATHCKE B. J. 1984. Patterns of flowering phenologies: testability and causal inference using a random model. – In: D. R. STRONG, Jr., D. SIMBERLOFF, L. G. ABELE & A. B. THISTLE (eds), Ecological communities: conceptual issues and the evidence, pp. 383–393. Princeton University Press, Princeton.
- REJEWSKI M. 1981. Roślinność jezior Rejonu Laski w Borach Tucholskich [Lake vegetation of the Laski Region in the Tuchola Forests]. 178 pp. Rozpr. Uniw. Mikołaja Kopernika, Toruń: (in Polish with English summary).

- REJMÁNEK M. 1977. The concept of structure in phytosociology with references to classification of plant communities. – *Vegetatio* **35**(1): 55–61.
- REJMÁNKOVÁ E. 1974. Biology of duckweeds in a Pannonian fishpond. – *Symp. Biol. Hung.* **15**: 125–131.
- ROBERTS A. & STONE L. 1990. Island-sharing by archipelago species. – *Oecologia* **83**: 560–567.
- ROBERTS D. W. 1987. A dynamical systems perspective on vegetation theory. – *Vegetatio* **69**(1–3): 27–33.
- ROUGHGARDEN J. 1983. Competition and theory in community ecology. – *Amer. Naturalist* **122**(5): 583–601.
- ROUGHGARDEN J. & DIAMOND J. 1986. Overview: The role of species interactions in community ecology. – In: J. DIAMOND & T. J. CASE (eds), *Community ecology*, pp. 333–342. Harper & Row, New York.
- RUMMEL J. D. & ROUGHGARDEN J. 1983. Some differences between invasion-structured and coevolution-structured competitive communities – *Oikos* **41**(3): 477–486.
- SALT G. W. 1979. A comment on the use of the term *emergent properties*. – *Amer. Naturalist* **113**(1): 145–148.
- SCHAFFER W. M. 1987. Chaos in ecology and epistemology. – In: H. DEGN, A. V. HOLDEN & L. F. OLSEN (eds), *Chaos in biological systems*, pp. 233–248. Plenum Press, New York – London.
- SCHEINER S. M. 1993. Introduction: theories, hypotheses, and statistics. – In: S. M. SCHEINER & J. GUREVITCH (eds), *Design and analysis of ecological experiments*, pp. 1–13. Chapman & Hall, New York – London.
- SCHLUTER D. 1984. A variance test for detecting species associations, with some applications. – *Ecology* **65**(4): 998–1005.
- SCHOENER T. W. 1983. Field experiments on interspecific competition. – *Amer. Naturalist* **122**(2): 240–285.
- SCHOENER T. W. 1986. Overview: Kinds of ecological communities – ecology becomes pluralistic. – In: J. DIAMOND & T. J. CASE (eds), *Community ecology*, pp. 467–479. Harper & Row, New York.
- SCHWABE-BRAUN A. & TÜXEN R. 1981a. Zur systematik der Klasse *Lemnetea minoris* in Europe. – *Ber. Int. Symp. Int. Ver. Vegk., Rinteln* **1980**: 181–205.
- SCHWABE-BRAUN A. & TÜXEN R. 1981b. *Lemnetea minoris*. Prodrömus der europäischen Pflanzengesellschaften **4**. 141 pp. Cramer, Vaduz.
- SCOPPOLA A. 1982. Considérations nouvelles sur végétations des *Lemnetea minoris* (R. Tx. 1955) em. A. Schwabe et R. Tx. 1981 et contribution l'étude de cette classe en Italie centrale. – *Doc. Phytosoc.* **6**: 1–130.
- SCOTT J. T. 1974. Correlation of vegetation with environment: a test of the continuum and community-type hypotheses. – In: B. R. STRAIN & W. D. BILLINGS (eds), *Vegetation and environment*. – In: *Handbook of Vegetation Science*. **6**, pp. 89–109. W. Junk, The Hague.
- SCULTHORPE C. D. 1967. *The biology of aquatic plants*. xviii + 610 pp. Edward Arnold, London.
- SEGAL S. 1968. Ein Einteilungsversuch der Wasserpflanzen-gesellschaften. – In: R. TÜXEN (ed.), *Pflanzensoziologische Systematik. Bericht über das Internationale Symposium in Stolzenau/Weser 1964*, pp. 191–211. W. Junk, Den Haag.
- SHELDON S. P. 1987. The effects of herbivorous snails on submerged macrophyte communities in Minnesota lakes. – *Ecology* **68**(6): 1920–1931.
- SHIPLEY B. & KEDDY P. A. 1987. The individualistic and community-unit concepts as falsifiable hypotheses. – *Vegetatio* **69**(1–3): 47–55.
- SIEGEL S. 1956. *Nonparametric statistics: for the behavioral sciences*. xvii + 312 pp. McGraw-Hill Kogakusha, Tokyo – Düsseldorf – Johannesburg – London.
- SILVERTOWN J. & WILSON J. B. 1994. Community structure in a desert perennial community. – *Ecology* **75**(2): 409–417.

- SILVERTOWN J. W. 1983. The distribution of plants in limestone pavement: test of species interactions and niche separation against null hypothesis. – *J. Ecol.* **71**(3): 819–828.
- SIMBERLOFF D. 1978. Using island biogeographic distributions to determine if colonization is stochastic. – *Amer. Naturalist* **112**: 713–726
- SIMBERLOFF D. 1983. Competition theory, hypothesis-testing, and other community ecological buzzwords. – *Amer. Naturalist* **122**(5): 626–635.
- SIMBERLOFF D. & CONNOR E. F. 1979. Q-Mode and R-Mode analyses of biogeographic distributions: null hypotheses based on random colonization. – In: G. P. PATIL & M. L. ROSENZWEIG (eds), *Contemporary quantitative ecology and related econometrics*, pp. 123–138. Int. Co-operative Publ. House, Bourtonsville.
- SIMBERLOFF D. & CONNOR E. F. 1981. Missing species combinations. – *Amer. Naturalist* **118**(2): 215–239.
- SIMBERLOFF D. & DAYAN T. 1991. The guild concept and the structure of ecological communities. – *Annual Rev. Ecol. Syst.* **22**: 115–143.
- SLAVNIĆ Z. 1956. Die Wasser- und Sumpfvvegetation der Vojvodina. – *Zbornik Matice (Novi sad)* **10**: 5–72.
- SMALLWOOD K. S. 1993. Understanding ecological pattern and process by association and order. – *Acta Oecologica* **14**(3): 443–462.
- SOKAL R. R. & ROHLF F. J. 1981. *Biometry. The principles and practice of statistics in biological research*. Ed. 2. xviii + 859 pp. W. H. Freeman, New York.
- SOUTHWOOD T. R. E. 1987. The concept and nature of the community. – In: J. H. R. GEE & P. S. GILLER (eds), *Organization of communities. Past and present*, pp. 3–27. Blackwell, Oxford.
- SPENCE D. H. N. 1967. Factors controlling the distribution of freshwater macrophytes with particular reference to the lochs of Scotland. – *J. Ecol.* **55**(1): 147–170.
- STARFINGER U. 1985. Pleustophyten und Wasserchemismus Untersuchungen an Berliner Pfulen. – *Verh. Berliner Bot. Vereins* **4**: 79–99.
- STONE L. & EZRATI S. 1996. Chaos, cycles and spatiotemporal dynamics in plant ecology. – *J. Ecol.* **84**(2): 279–291.
- STONE L. & ROBERTS A. 1990. The checkerboard score and species distribution. – *Oecologia* **85**: 74–79.
- STRAUSS R. E. 1982. Statistical significance of species clusters in association analysis. – *Ecology* **63**(3): 634–639.
- STRONG D. R. 1980. Null hypothesis in ecology. – *Synthese* **43**: 271–285.
- STRONG D. R. 1983. Natural variability and the manifold mechanisms of ecological communities. – *Amer. Naturalist* **122**: 636–660.
- STRONG D. R., Jr., SIMBERLOFF D., ABELE L. G. & THISTLE A. B. (eds) 1984. *Ecological communities: conceptual issues and the evidence*. xiii + 613 pp. Princeton University Press, Princeton.
- STUGREN B. 1976. *Zasady ekologii ogólnej [Grundlagen der Allgemeine Ökologie]*. 210 pp. Państwowe Wydawnictwo Naukowe, Warszawa (in Polish translated from German).
- SUGIHARA G. & MAY R. M. 1990. Nonlinear forecasting as a way of distinguishing chaos from measurement error in time series. – *Nature* **344**: 734–741.
- TANSLEY A. G. 1920. The classification of vegetation and concepts of development. – *J. Ecol.* **8**: 118–149.
- TANSLEY A. G. 1935. The use and abuse of vegetational concepts and terms. – *Ecology* **16**(3): 284–307.
- TAYLOR W. D. 1979. Sampling data on the bacterivorous ciliates of a small pond compared to neutral models of community structure. – *Ecology* **60**(5): 876–883.
- TILMAN D. 1989. Resources, competition and the dynamics of plant communities. – In: M. J. CRAWLEY (ed.), *Plant ecology*, pp. 51–75. Blackwell, Oxford.
- TOMASZEWICZ H. 1969. Roślinność wodna i szuwarowa starorzeczy Bugu na obszarze województwa

- warszawskiego [The water and swamp vegetation of closed meanders of river Bug in Warsaw region]. – Acta Soc. Bot. Pol. **38**(2): 217–245 (in Polish with English summary).
- TOMASZEWICZ H. 1973. The position of *Scirpo-Phragmitetum* W. Koch 1926 in systematics. – Acta Soc. Bot. Pol. **42**(3): 379–390.
- TOMASZEWICZ H. 1977a. Roślinność wodno-bagienna w akwenach zlewni Skrwy i Ciechomickiej na Pojezierzu Gostynińskim [Aquatic and bog vegetation in the reservoirs of the Ciechomice and Skrwa drainage area on the Gostynin Lakeland]. – Monogr. Bot. **52**: 1–142 (in Polish with English summary).
- TOMASZEWICZ H. 1977b. Proposal of new syntaxonomic classification of *Myriophyllo-Nupharetum* W. Koch 1926 phytocoenoses and their distribution in Poland. – Acta Soc. Bot. Pol. **46**(3): 423–436.
- TOMASZEWICZ H. 1980. Roślinność wodna i szuwarowa Polski (klasy: *Lemnetea*, *Charetea*, *Potamogetonetea*, *Phragmitetea*) wg stanu zbadania na rok 1975 [Aquatic and rush vegetation of Poland (Classes: *Lemnetea*, *Charetea*, *Potamogetonetea*, *Phragmitetea*) according to the state of investigations for the year 1975]. 324 pp. Wydawnictwo Uniwersytetu Warszawskiego, Warszawa (in Polish with English summary).
- TOWNSEND C. R. 1989. The patch dynamics concept of stream community ecology. – J. N. Am. Benthol. Soc. **8**: 36–50.
- TÜXEN R. 1974. Die Pflanzengesellschaften Nordwestdeutschlands. ix + 207 pp. J. Cramer, Lehre.
- UNDERWOOD A. J. 1986. What is a community? – In: D. M. Raup & D. Jablonski (eds), Patterns and process in the history of life, pp. 351–367. Springer, Berlin.
- VAN DER MAAREL E. 1975. The Braun-Blanquet approach in perspective. – Vegetatio **30**(3): 213–219.
- VAN DER VALK A. G. 1981. Succession in wetlands: a Gleasonian approach. – Ecology **62**(3): 688–696.
- VAN DER VALK A. G. 1987. Vegetation dynamics of freshwater wetlands: a selective review of the literature. – Arch. Hydrobiol. Beih. Ergebn. Limnol. **27**: 27–39.
- VAN DER VALK A. G. & DAVIS C. B. 1978. The role of seedbanks in the vegetation dynamics of prairie glacial marshes. – Ecology **59**(2): 322–335.
- VAN VALEN L. M. 1982. Why misunderstand the evolutionary half of biology? – In: E. SAARINEN (ed.), Conceptual issues in ecology, pp. 323–343. D. Reidel, Dordrecht.
- WEIHER E. & KEDDY P. A. 1995a. The assembly of experimental wetland plant communities. – Oikos **73**(3): 323–335.
- WEIHER E. & KEDDY P. A. 1995b. Assembly rules, null models, and trait dispersion: new questions from old patterns. – Oikos **74**(1): 159–164.
- WERGER M. J. A. 1974. The place of the Zürich-Montpellier method in vegetation science. – Folia Geobot. Phytotax. **9**(1): 99–109.
- WESTMAN W. E. 1983. Xeric Mediterranean-type shrubland associations of Alta and Baja California and the community/continuum debate. – Vegetatio **52**(1): 3–19.
- WESTHOFF V. & VAN DER MAAREL E. 1978. The Braun-Blanquet approach. – In: R. H. WHITTAKER (ed.), Classification of plant communities, pp. 287–399. W. Junk, The Hague.
- WHITTAKER R. H. 1956. Vegetation of the Great Smoky Mountains. – Ecol. Monogr. **26**: 1–80.
- WHITTAKER R. H. 1962. Classification of natural communities. – Bot. Rev. **28**: 1–239.
- WHITTAKER R. H. 1967. Gradient analysis of vegetation. – Biol. Rev. **42**: 207–264.
- WHITTAKER R. H. (ed.) 1978a. Classification of plant communities. 408 pp. W. Junk, The Hague – Boston.
- WHITTAKER R. H. (ed.) 1978b. Ordination of plant communities. 388 pp. W. Junk, The Hague – Boston.
- WIEGLEB G. 1989. Explanation and prediction in vegetation science. – Vegetatio **83**(1–2): 17–34.

- WIENS J. A. 1976. Population responses to patchy environments. – *Annual Rev. Ecol. Syst.* **7**: 81–120
- WIENS J. A. 1984. On understanding a non-equilibrium world: myth and reality in community patterns and processes. – In: D. R. STRONG, JR., D. SIMBERLOFF, L. G. ABLE & A. B. THISTLE (eds), *Ecological communities: conceptual issues and the evidence*, pp. 439–457. Princeton University Press, Princeton.
- WIENS J. A. 1986. Spatial scale and temporal variation in studies of shrubsteppe birds. – In: J. DIAMOND & T. J. CASE (eds), *Community ecology*, pp. 154–174. Harper & Row, New York.
- WIENS J. A. 1989. Spatial scaling in ecology. – *Funct. Ecol.* **3**: 385–397.
- WIENS J. A., ADDICOTT J. F., CASE T. J. & DIAMOND J. 1986. Overview: the importance of spatial and temporal scale in ecological investigations. – In: J. DIAMOND & T. J. CASE (eds), *Community ecology*, pp. 145–153. Harper & Row, New York – Cambridge – Philadelphia etc.
- WILLIAMS C. B. 1947. The generic relations of species in small ecological communities. – *J. Anim. Ecol.* **16**: 11–18.
- WILLIAMS C. B. 1951. Intra-generic competition as illustrated by Moreau's records of East African birds. – *J. Anim. Ecol.* **20**: 246–253.
- WILLIAMS C. B. 1964. *Patterns in the balance of nature and related problems in quantitative ecology*. vi + 324 pp. Academic Press, London.
- WILSON J. B. 1987. Methods for detecting non-randomness. – *Oecologia* **73**: 579–582.
- WILSON J. B. 1988. Community structure in the flora of islands in Lake Manapouri, New Zealand. – *J. Ecol.* **76**(4): 1030–1042.
- WILSON J. B. 1989. Relations between native and exotic plant guilds in the Upper Clutha, New Zealand. – *J. Ecol.* **77**(1): 223–235.
- WILSON J. B. 1991. Does vegetation science exist? – *J. Veg. Sci.* **2**(3): 289–290.
- WILSON J. B. 1994. Who makes the assembly rules? – *J. Veg. Sci.* **5**(2): 275–278.
- WILSON J. B. 1995. Null models for assembly rules: the Jack Horner effect is more insidious than the Narcissus effect. – *Oikos* **72** (1): 139–144.
- WILSON J. B. & ALLEN R. B. 1990. Deterministic versus Individualistic community structure: a test from invasion by *Nothofagus menziesii* in Southern New Zealand. – *J. Veg. Sci.* **1**(4): 467–474.
- WILSON J. B. & GITAY H. 1995. Community structure and assembly rules in a dune slack: variance in richness, guild proportionality, biomass constancy and dominance/diversity relations. – *Vegetatio* **116**(2): 93–106.
- WILSON J. B. & SYKES M. T. 1988. Some tests for niche limitation by examination of species diversity in the Dunedin area, New Zealand. – *New Zealand J. Bot.* **26**: 237–244.
- WILSON J. B. & WHITTAKER R. J. 1995. Assembly rules demonstrated in a saltmarsh community. – *J. Ecol.* **83**(5): 801–807.
- WILSON J. B., JAMES R. E., NEWMAN J. E. & MYERS T. E. 1992. Rock pool algae: species composition determined by chance? – *Oecologia* **91**(1): 150–152.
- WIMSATT W. C. 1982. Randomness and perceived-randomness in evolutionary biology. – In: E. SAARINEN (ed.), *Conceptual issues in ecology*, pp. 279–321. D. Reidel, Dordrecht.
- WOLDA H. 1987. Seasonality and the community. – In: J. H. R. GEE & P. S. GILLER (eds), *Organization of communities. Past and present*, pp. 69–95. Blackwell, Oxford.
- WOLFF P. & LANDOLT E. 1994. Spread of *Lemna turionifera* (Lemnaceae), the red duckweed, in Poland. – *Fragm. Flor. Geobot.* **39**(2): 439–451.
- WOLNY P. 1956. Wpływ stada kaczek na biocenozę stawów karpowych [Der Einfluss der Enten auf die Biocoenose der Karpfenteiche]. – *Biul. Zakładu Biol. Stawów Polska Akad. Nauk* **3**: 47–67.

- WOLEK J. 1974a. Kritische Übersicht der Pleustongesellschaften Polens (Klasse *Lemnetea*). – *Fragm. Flor. Geobot.* **20**(3): 365–379.
- WOLEK J. 1974b. A preliminary investigation on interactions (competition, allelopathy) between some species of *Lemna*, *Spirodela* and *Wolffia*. – *Ber. Geobot. Inst. ETH Stiftung Rübel Zürich* **42**: 140–162.
- WOLEK J. 1979. Experimental investigations on competition and allelopathy between *Spirodela polyrrhiza* (L.) Schleid. and *Wolffia arrhiza* (L.) Wimm. – *Fragm. Flor. Geobot.* **25**(2): 281–350.
- WOLEK J. 1981. Assessment of the possibility of exoornithochory of duckweeds (Lemnaceae) in the light of researches into the resistance of these plants to desiccation. – *Ekol. Pol.* **29**(3): 405–419.
- WOLEK J. 1983. Determinants of community structure for the pleustonic plants (the *Lemnetea* class). – *Ekol. Pol.* **31**(1): 173–200.
- WOLEK J. 1984. Intraspecific variation and the competitive abilities of *Spirodela polyrrhiza* (L.) Schleiden. – *Ekol. Pol.* **32**(4): 637–649.
- WOLEK J. 1988. Null hypothesis in studies on plant communities. I. Null model, research procedure, statistical analysis of results. – *Ekol. Pol.* **36**(3–4): 471–484.
- WOLEK J. 1991. Synusial assemblages of pleustonic plants of genera: *Lemna*, *Spirodela*, *Wolffia*, *Salvinia*, *Hydrocharis*, *Riccia* and *Ricciocarpus*. – *Ber. Geobot. Inst. ETH Stiftung Rübel Zürich* **57**: 193–202.
- WOLEK J. & DAWIDOWICZ A. L. 1991. Rozkłady ucięte, dwumianowy i Poissona, w badaniach ekologicznych: zastosowanie praktyczne [Truncated binomial and Poisson distributions in ecological studies: a practical application]. – *Wiad. Ekol.* **37**(1): 27–41 (in Polish with English summary).
- WOLEK J. & PANCER-KOTEJOWA E. 1988. Null hypothesis in studies on plant communities. II. Assemblages of species of the genus *Luzula*. – *Ekol. Pol.* **36**(3–4): 485–507.
- WRIGHT S. J. & BIEHL C. C. 1983. Empty sites and analysis of presence-absence data. – *Amer. Naturalist* **122**: 833–834.
- YODZIS P. 1986. Competition, mortality, and community structure. – In: J. DIAMOND & T. J. CASE (eds), *Community ecology*, pp. 480–491. Harper & Row, New York.
- YULE G. U. 1927. On a method of investigating periodicities in disturbed series, with special reference to Wolfer's sunspot numbers. – *Philosophical Transactions of the Royal Society A* **226**: 267–298.
- ZASEPA R. 1962. Badania statystyczne metodą reprezentacyjną. Zarys teorii i praktyki [“Statistical investigation by means of representative method. Introduction to theory and practice”]. 372 pp. Państwowe Wydawnictwo Naukowe, Warszawa (in Polish).
- ZIMMERMANN M. A. 1981. Einfluss von Calcium und Magnesium auf das Wachstum von mitteleuropäischen Lemnaceen-Arten. – *Ber. Geobot. Inst. ETH Stiftung Rübel Zürich* **48**: 120–160.
- ZOBEL K. & ZOBEL M. 1988. A new null hypothesis for measuring the degree of plant community organization. – *Vegetatio* **75**(1): 17–25.

Received 2 December 1996, Accepted 28 February 1997